



KELP NURSERY OPERATIONS MANUAL

Proven Protocols and Practices for Seed Cultivation



Contents

01 GETTING STARTED	1
Introduction	2
Guidelines	3
Cleaning and Sterilization	4
Cleaning Lab Supplies	4
Biosecurity	5
<hr/>	
02 NURSERY INFRASTRUCTURE	6
Overview	7
Water	8
Holding Water	10
Water Processing	11
Envelope	20
Cooling	22
Lighting	23
Grow Tank Setup	24
<hr/>	
03 PRE-SEEDING PREPARATION	27
Cutting and Sanitizing Spools	28
Protocol for Sanitizing Spools	30
Winding and Soaking Spools	32
Protocol for Soaking Spools	34
Tank and Water System Cleaning	36
<hr/>	
04 MAKING MEDIA AND OTHER SOLUTIONS	38
Protocol for Preparing Solutions	40
<hr/>	
05 SOURCING SORUS MATERIAL	42
Protocol for Packaging and Shipping Sorus Tissue	46
<hr/>	
06 SORUS PROCESSING	48
Protocol for Processing Sorus Tissue	50

07 SEEDING SPOOLS	52
Protocol for Seeding Spools	54
<hr/>	
08 CARING FOR SPOOLS IN THE NURSERY	56
Environmental Conditions Check	58
Health Check	60
Equipment/System Check	61
Troubleshooting	62
<hr/>	
09 SEED ORDERING	63
Sample Farmer-Nursery Seed Spool Contract	66
Transporting Seed Spools	67
Protocol for Seed Spool Transportation	68
<hr/>	
10 REFERENCE DOCUMENTS	70
Environmental Conditions Chart	71
Contamination Treatment Chart	72
Greenwave Water System and Nursery Diagram	74
Contamination Identification for Spools	75
Spool Growth Tracking Chart	79
Seed Spool Quality Grading Guidelines	80
Media and Solutions Chart	81

PART 01

GETTING STARTED



GETTING STARTED

Introduction

These procedures outline nursery methods that have been tried and tested on sugar kelp (*Saccharina latissima*) in the North Atlantic. The guidance here reflects what works best for this species in this region, but the core principles outlined, including the basic principles of water filtration and sanitation, apply broadly to kelp nurseries regardless of species or region. Minor adjustments may be needed for other species or locations, and notes are included throughout to help anticipate where adaptations may be useful. These tips are not comprehensive, but they provide a foundation for recognizing when and how methods may need to be adjusted.

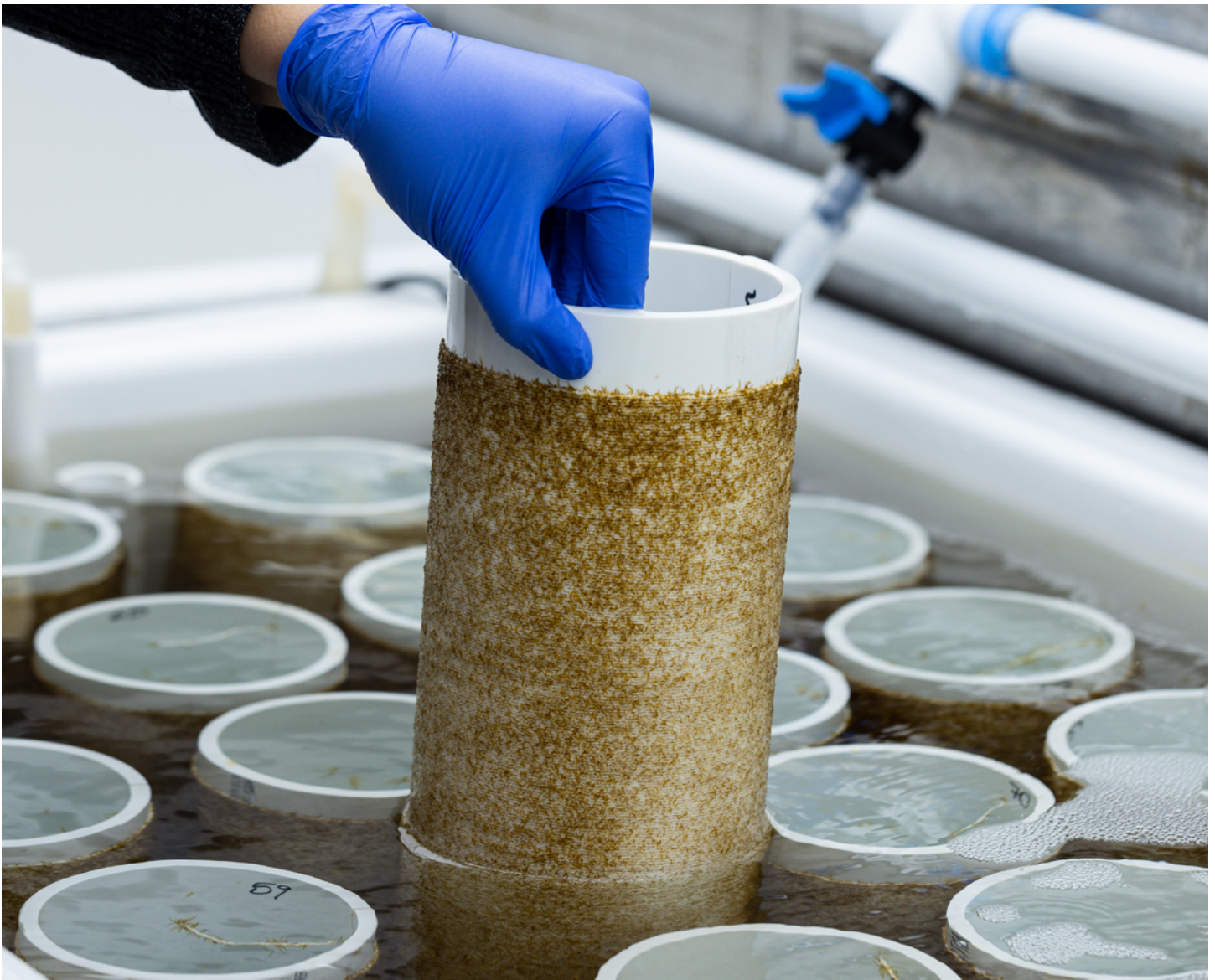

GETTING STARTED

Guidelines

Your nursery tank is tailored to be the perfect environment for your kelp seed to grow. Unfortunately, many other organisms also thrive in this environment. If not properly managed or contained, contamination in your nursery can quickly spiral out of control. You need to be hypervigilant about keeping surfaces and equipment clean to reduce the risk of contamination.

Set yourself up for success by adhering to the following guidelines in all of your nursery activities:

1. **Familiarize yourself with important processes and systems**, especially sterilization protocols and your water filtration system, so you can make intuitive decisions and avoid preventable nursery failures.
2. **Follow the sorus tissue processing protocols carefully.** Microscopic organisms living on your sorus tissue are the most common way contaminants enter your facility.
3. **Wear nitrile gloves when working in a tank.** As soon as you move to another tank, switch gloves or spray the gloves with 70% (or higher) ethanol, and wipe your gloves with a clean paper towel. This prevents cross-contamination between tanks. If you use ethanol, always be sure your gloves are completely dry before continuing work; even a small amount of ethanol can harm your kelp. **If a tank is contaminated, always switch gloves before working on another tank.**
4. **Take care of your filtration system.** Filtration helps keep your seawater sterile. Follow the manufacturer's instructions on how to properly clean your filtration system. Store it properly at the end of the season to ensure its longevity.
5. **Keep the doors and windows leading to your nursery space closed.** This will help keep dust, grime, and microorganisms out of your sterile space.
6. **Use air filtration systems** like small in-line filters for any aeration into your tanks.
7. **Do not enter your space in clothes or shoes that are dirty from farm work** or have recently been in contact with raw seawater.
8. **Thoroughly sterilize and clean all equipment before placing it in your tanks.** Spray or wipe any equipment that regularly moves from tank to tank (such as water quality probes) with 70% (or higher) ethanol solution between uses. Be sure they are completely dry before using them in the next tank.

GETTING STARTED

Cleaning and Sterilization

Generally, the cleaning and sterilization of all of your equipment in the nursery can be distilled into four steps: scrub, sterilize, neutralize, and rinse. These steps differ slightly depending on what you are working with but are all imperative. Scrubbing helps to remove excess biomass or biofilm from the surfaces and allows for the sterilization to reach all the nooks and crannies. If something has a heavy biofilm, which can easily build up over the course of a nursery season, bleach may not penetrate through the film. Sterilization can be done using bleach, ethanol, steam, or UV; the method depends highly on intended use and space constraints. If you are sterilizing using bleach, it is important to neutralize using sodium thiosulfate. Rinsing with sterile seawater is important to make sure no residual chemicals are left on your equipment. Tank systems and cultures can be delicate and excess chemicals can have drastic impacts. To maintain efficiency during routine cleaning, it can be helpful to keep duplicates of frequently used items so one set is available while the other is being sterilized.



Take apart every possible part of your tank and nursery system to clean it entirely. The water pumps can be broken down into six parts for thorough cleaning.

Cleaning Lab Supplies

Along with keeping your nursery clean, it is also very important to keep any smaller lab equipment clean. The general process for cleaning lab supplies like beakers, flasks, etc. is to scrub, rinse, steam, dry, ethanol, and rinse with sterile seawater. The steaming step can be done in an autoclave or any dishwasher with a steam setting. Soak the equipment in freshwater from the point of use up until washing, and always scrub and rinse equipment before putting them into a steam sterilizer or dishwasher. Once the items steam, leave them to dry in a clean space like a hood, and then store them in a clean cabinet or tote. Before using the equipment, spritz it with ethanol, wipe the ethanol, and then rinse with sterile seawater at least two times. Excess ethanol can have negative effects on kelp.

GETTING STARTED

Biosecurity

Biosecurity in the nursery and lab spaces is essential to providing appropriate seed to farmers. This should be a consideration from initial sorus collection to when farmers pick up their seed. Along with mitigating contamination outbreaks, good biosecurity is important for permitting reasons. Seed from different regions or collection locations and different species should all be kept separate. Regulatory rules might prohibit farmers from planting seed from outside a given area, so it is important for seed suppliers to ensure the seed given to farmers is within regulatory guidelines. Separate your seed in tanks based on their source and species. Plan your nursery setup with this in mind.

In addition to tank separation in the nursery, biosecurity is very important during sorus collection and release. When sorus is collected from multiple locations in a day, it is important to keep the blades from each location separate while processing and releasing. During processing, clean containers should be used for each location. If you are using the dip method, make new baths between locations. Once the sorus is processed, store different locations in separate vessels or with multiple layers of paper towels between. When you are releasing, take special care to make sure no cross contamination occurs. One drop of release water can easily carry hundreds of meiospores.

“

“You are a source of contamination. It’s on your clothes, skin, and hair. Try to be diligent about using a foot bath, washing your hands, using gloves, and changing clothes or putting a lab coat on when entering the nursery.”

— **Thew Suskiewicz**

Atlantic Sea Farms, Maine



Gametophyte culture with a unique label that indicates the species, collection location, individual sporophyte, and age of the culture. The label also includes a culture number for easier identification during maintenance.

PART 02

NURSERY INFRASTRUCTURE



NURSERY INFRASTRUCTURE

Overview

Nursery infrastructure can make or break a season. Diligent sorus processing, spore release protocols, and intense water processing can help to mitigate contamination, but without the appropriate water filtration, cooling, and environmental conditions, the work you do to prepare your sorus can be undermined by the introduction of contaminants.

In this section, we walk through the necessary infrastructure to achieve ideal conditions in the nursery and maintain a high level of control over the introduction of contaminants to your grow tanks. We cover sourcing and processing water, the nursery envelope, cooling, grow tanks, and lighting.



NURSERY INFRASTRUCTURE

Water

A successful nursery has two primary water requirements:

1. Highly filtered and sterilized water
2. Easy breakdown of the water system for sanitization and cleaning

Without clean water, the nursery operator has very little control over the introduction of contaminants into tanks.

Sourcing Clean Water

A reliable source of seawater is essential for running a nursery and keeping kelp gametophytes. Sourcing water can be difficult because of geographical, time, and/or space constraints. When possible, source seawater from an area with salinity between 28 and 35 ppt and an input at least 10 feet deep. Adjusting salinity in the nursery can be difficult and time consuming. Water taken from depth is more favorable because it is typically cleaner than water taken from the surface. Additionally, steer clear of areas near heavy industrial discharges or human development due to contamination concerns. For the best water quality, collect seawater during a rising tide to minimize turbidity levels, which will reduce the need for extensive filtration. If your intake site is near a significant source of fresh water like a river, salinity needs to be checked after rain events. You have two primary options for sourcing water: an existing intake pipe or open waters.

Ideally, you are able to set your facility up near a water source so you can pump water directly into your filtration system. Otherwise, you will need to transport water. If you don't have access to an existing intake pipe, a **gas powered suction pump** can come to your rescue. Use a rigid **suction hose** for the pump's intake side and a **flexible hose** for the discharge side. Before first use, flush the hose with saltwater for several hours to remove any manufacturing residues. Regardless of whether you are transporting water or pumping it directly into your system, your water should pass through a **sand filter** before being put through a smaller micron bag or cartridge filter.

NURSERY INFRASTRUCTURE

Transporting water will be time and resource consuming. Some regions have services for hire that will transport water for you, but it is typically costly. For a smaller tank system, you may only use 50 gallons a week, but for a larger nursery, you may use up to 3,000 gallons in a week. If you elect to transport your own water, you will need specialized containers, like a [275 gallon IBC tote](#), as well as a heavy duty truck to transfer large amounts of water. Weighing in at more than 8 pounds a gallon, it's critical to make sure the vehicle being used to transport water has an appropriate capacity rating for the volume of water being moved.

If you're buying a used tote, make sure it was previously used for food-safe purposes. To prepare the tote for seawater, leach it with fresh water for 24 hours, and then leach it with seawater for 24 hours. To expedite filling and emptying the tote, a [hatch](#) should be cut into the top—this allows for inserting a high-volume [sump pump](#) directly into the tote. The pump linked is not rated for saltwater to reduce cost—after each use it needs to be rinsed thoroughly by running fresh water through the pump to flush out any corrosive material.

If sourcing natural seawater is not possible for your facility, some nurseries have been successful using an artificial seawater mix. Water made this way requires some additional testing to ensure the composition is as close to the natural seawater in your region as possible. There are a few manufacturers of ready-to-mix artificial seawater. The most common one is [Instant Ocean](#). Some operators have experienced variability between artificial seawater, and the fresh water used may require pre-treatment such as reverse osmosis or carbon filtration depending on the source.



NURSERY INFRASTRUCTURE

Holding Water

The size of your facility and your water usage will determine the size of your water storage containers. You will need multiple containers to store your water during the different phases of the filtration and sterilization processes. It is important that the containers do not allow light to pass through—excess light will allow contaminants to grow. Although a tank may look opaque, it often is letting a little light through; shine a strong flashlight from the inside out to check that your tank is not letting any light through. If needed, heavy duty paint can be applied to the outside until there is no light coming in.

Refer to the [Seed Production Pathways to Scale](#) course on the [Ocean Farming Hub](#) to learn more about how GreenWave stores and cools water. Within this course, you will also find a build list which contains links to the necessary equipment.

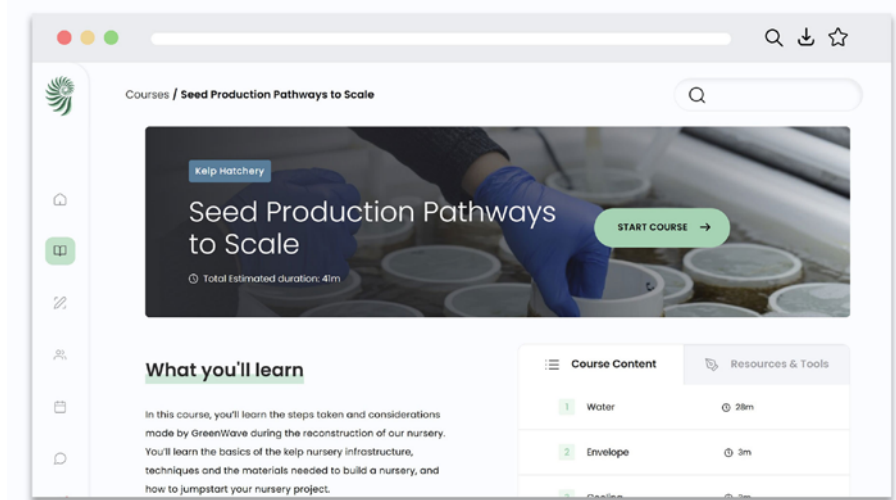

The first container will hold the raw water after it is unloaded, the second container will be used for skimming and other chemical treatments, and the third container will hold water that has passed through the mechanical filtration and UV and is now considered clean. From there, water can be used for seed tanks and gametophyte cultures. For a system like GreenWave’s container nursery, you need a holding tank inside the chilled area where the sterilized water can be tempered from ambient temperature to the target temperature of the grow tanks to avoid thermal shock. For a system of tanks that are chilled using a separate cooling source, use [aquarium chillers](#).

NURSERY INFRASTRUCTURE

Water Processing

Inside your facility, you'll need to create the perfect marine environment for kelp growth by removing contamination, organic matter, and any other living organisms from the water. To ensure ease of maintenance and minimize contamination risks, construct the water processing system so it can be completely disassembled and thoroughly scrubbed between seasons. Use unions in pressure sections of the piping for easy separation. When connecting pipes that are 5 PSI or less, we employ Teflon tape for leak-proof connections, wrapping the pipe end several times with heavy duty (extra thick) Teflon and then pressing it into the fitting. Be aware that Teflon tape is for one-time use; you'll need to remove and reapply it after each annual cleaning. To circulate and transfer water within the system, use Eheim pumps. These mag drive pumps are ideal for seawater use as they don't expose seals or ferrous materials to the water. These pumps are submersible and have threaded female fittings for inline use.



NURSERY INFRASTRUCTURE

We break water processing down into four main steps/loops:

1. Initial filtration
2. Protein fractionation and ozone loop
3. Polishing filtration loop
4. Tempering (cooling) and circulation to grow tanks

Many of these steps are continuous loops so that the seawater is not sitting stagnant at any time. Water motion helps to mitigate contamination buildup, oxygenate the water, and ensures continuous filtration.

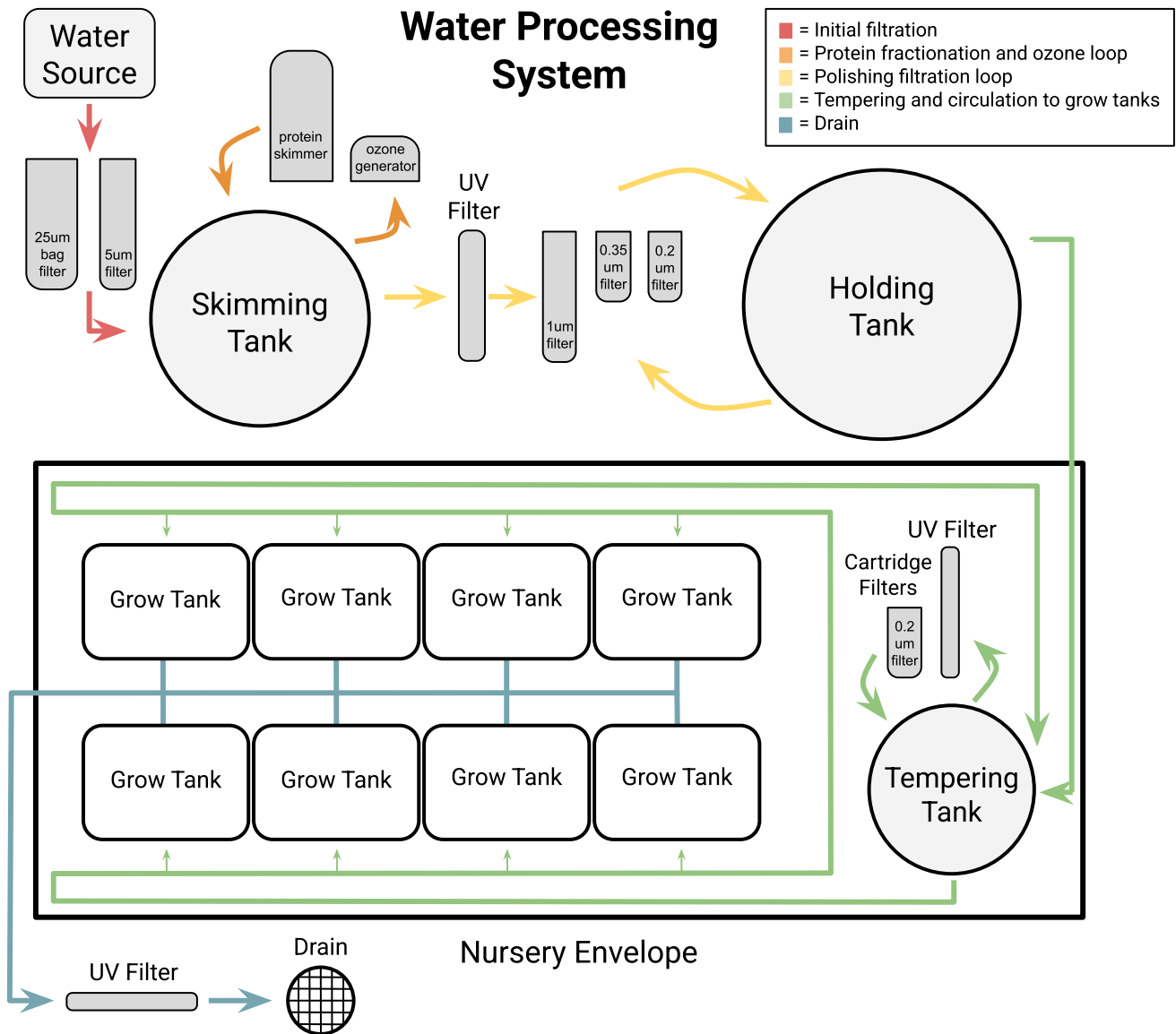

NURSERY INFRASTRUCTURE

Initial Filtration

Begin the water treatment process by removing large particles using a sand filter. Connect the sump pump inside the raw water transport vessel (such as an IBC) to a **20" bag filter housing** with a **25 micron filter**. Attach this housing to a **20" cartridge filter housing** with a **5 micron cartridge filter**. After each 500-gallon load of water is filtered, rinse the filter media with fresh water. **Pressure gauges** ($\frac{1}{4}$ " NPT 2.5" gauges with 0–30 scale) on the filter housings will help you monitor their performance; higher pressure readings indicate when a filter cartridge may need to be replaced. Ensure all wetted elements of the gauge are made of 316 stainless steel to prevent toxic metal contamination. This filter media should be thoroughly rinsed with fresh water after use, and when they start to degrade in appearance should be replaced. We have found they last well for up to 10,000 gallons of filtration, but this will depend on how clean your water source is. After this initial filtration, water is piped into a **500-gallon skimming tank**.



Bag filter and cartridge filter housing set up

NURSERY INFRASTRUCTURE

Protein Fractionation and Ozone

A crucial step in water processing involves using a [protein fractionator](#) or skimmer. The protein skimmer enhances water quality by a phenomenon called the Venturi effect, which injects air and ozone into the water, creating foam. This foam helps precipitate unwanted organic materials from the water. You can pump your water through the protein skimmer using a [protein skimmer pump](#).

- 1. Positioning:** The pipe that releases the cleaned water from the skimmer should always be above the highest water level inside the skimming tank. This ensures that the cleaned water doesn't mix with the untreated water.
- 2. Waste collection:** At the top of the protein skimmer, there's a compartment known as the "waste chamber". This area collects the impurities and contaminants removed from the water. To properly dispose of this waste, it can be directed to another container either through gravity or by using a pump.
- 3. Adjustments:** The protein skimmer allows for three key adjustments:
 - **Water input volume:** By changing the amount of water entering the skimmer, you can control the level of aeration generated by the Venturi effect. The goal is to produce just enough foam to reach the top of the waste chamber without causing an overflow. Too much aeration can lead to issues.
 - **Output valve:** This valve allows you to control the height of the foam column once you've adjusted the water input volume for a stable reaction.
 - **Ozone/aeration control:** By valving the air/ozone inlet to the skimmer, you can further control the size and volume of foam being created. A 0.2 micron inline filter should be used to prevent injecting contamination into the skimmer.
- 4. Pump compatibility:** To ensure the protein skimmer functions correctly, it's crucial to pair it with a pump that matches the recommended flow rate provided by the manufacturer.



From left to right: Positioning, waste collection, adjustments, top: water input volume, bottom: output valve, ozone/aeration control, and pump compatibility

NURSERY INFRASTRUCTURE

Treating the water with ozone will neutralize microorganisms that are still in the water. The protein skimmer will then remove waste and dissolved organic nutrients from the water, as well as help to balance the pH. The **ozone generator** is linked to the protein skimmer through its air input. This connection allows ozone to be introduced into the skimming process. While the water is being treated with the protein fractionator and ozone, it is being pumped in a continuous loop. Ozone can be harmful to people, so we take some precautions.

Most importantly, we use an **ozone alarm** to continuously monitor the level of ozone in the air. This ensures that the ozone levels around us stay safe. To maintain a safe environment and prevent ozone levels from becoming too high, we use an **Oxidation Reduction Potential (ORP) controller**. When the ORP levels in the skimming tank reach a set level of 600 millivolts (mV), the controller automatically turns off the ozone generator. ORP is a measure of water clarity, which we use as a proxy for ozone levels in the water. The ORP controller includes a remote probe suspended in the middle of the skimming tank. It's also connected to the power supply of the ozone generator. This set-up allows the controller to closely monitor the ozone levels and control the generator as needed, ensuring our safety while effectively treating water.



From left to right: Ozone generator, ozone alarm, and ORP controller

NURSERY INFRASTRUCTURE

The time it takes for the skimming process to finish depends on how much organic matter is in your water, and this can change based on the marine environment when you collect the water. On average, it might take anywhere from 36 to 48 hours. This process can be sped up with a larger ozone generator. You can tell when the process is done by these three indicators:

1. **Stable ORP Levels:** The first thing to check is the ORP level in the skimming tank. You want it to stay steady for at least 6 hours. It's normal for the ORP reading to go up and down a bit as the water circulates in the tank.
2. **Foam Appearance:** Look at the foam in the waste chamber. What you're aiming for is foam that doesn't have any little particles in it. The cleaner the foam, the better the skimming process is working. So, when you see clear foam without any organic matter in it, you know your water is getting really clean.
3. **Water Appearance:** When the protein skimming and ozonation process are complete, the water should have a bluish hue and faint smell of chlorine.



NURSERY INFRASTRUCTURE

Polishing Filtration

“

“Common contaminants like green microalgae often come from seawater that hasn't been filtered properly. Using a 0.2 micron cartridge filter goes a long way toward minimizing those issues.”

— **Maggie Aydlett**

GreenWave, Connecticut

After the skimming process is complete, the water will be **pumped** through a series of three **cartridge filters** going down to 0.2 microns. A pump with a flow rate of 910 gallons per hour and a 10-foot head is used to transfer water from the skimming tank to a larger 1,000-gallon **holding tank**. Along the way, the water passes through a **UV filter** and three mechanical filtration cartridges sizes **1 micron**, **0.35 micron**, and **0.2 micron** cartridge filters. The 0.2 micron filters are significantly more expensive than the others, so use the smallest filter size you can before them. We keep an eye on the system using **pressure gauges** on each filter housing to know when it's time to clean or replace the filters. A high pressure reading indicates resistance in the filter, suggesting the cartridge may need to be cleaned or replaced. Alternatively, you can use **water flow meters** to show when the flow rate has decreased due to clogged filters.

Any leftover contaminants will be filtered out at this point and your water is ready to use for rearing seed spools. Depending on your initial water quality, you may need to adjust the micron size of the filtration media, or possibly add an additional filter housing to support additional filters. We recommend a pasteurization step for water that will be used for gametophyte culturing.



*Pasteurization involves heating the water to between 170 and 190°F. GreenWave uses **4L HDPE carboys** and a coffee urn to do this, but any heat- and pressure-tolerant vessel and anything that can create a semi-temperature-steady water bath will do the trick. The amount of time you heat the water for depends on the volume. A good rule of thumb is 15 minutes for 1 liter and add 10 minutes for every additional liter. Heat the water twice for best results.*



Left: UV filter
Right: Filtration cartridges

NURSERY INFRASTRUCTURE

The transfer process between the skimming loop and the polishing loop is carefully monitored by the operator. When the skimming tank is almost empty, we use valves to stop the flow from the skimming tank and open a valve at the bottom of the holding tank on the polishing loop. This allows water to flow to the circulation pump, which is connected to both tanks through a T-shaped fitting.

At the top of the holding tank, there's another T fitting. This splits the water flow. Some of it goes back into the holding tank for recirculation, while the rest flows into the nursery for further use.

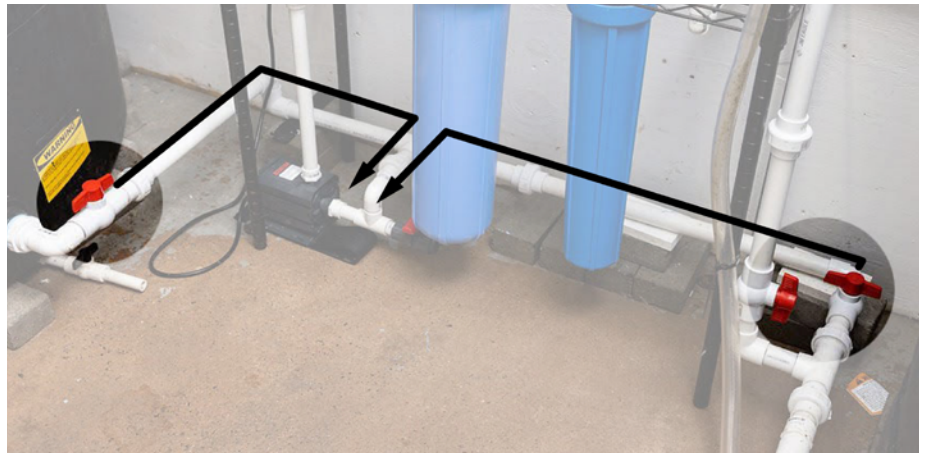

Tempering (Cooling) and Circulation to Grow Tanks

Once the water is pumped into the grow room it is tempered, filtered, and distributed. The water enters a **200-gallon tempering tank** in the nursery where it is cooled down to a temperature of 50 degrees Fahrenheit. If you are using aquarium chillers to cool water for your individual tanks, this system will look slightly different. At the bottom of the tempering tank, there's a **pump** that pushes the water through a **UV filter** and a **0.2-micron mechanical filter**. This is the same model of pump we use to circulate water through the holding tank filter train, so we are able to keep one spare on hand that can be installed at several points in the system.

The filtered water then travels along the pipes on the walls of the grow room. At each grow tank, there's an **emitter** that releases the cleaned water. If none of the emitters are open, the water continues in the loop and returns to the top of the tempering tank. This way, the water keeps moving through the system at all times. To keep an eye on how well the filters are doing, there's a **pressure gauge** installed.

NURSERY INFRASTRUCTURE

Details Really Matter

Water should never stagnate anywhere in the system. The system is designed for continuous water flow. Transfer legs and episodic pipes should have drain valving, and active circuits need to be designed so water can constantly circulate.

Every part of the processing and storage system needs to be lightproof (except the protein skimmer!). Don't assume dark tones or opaque-appearing materials will not pass light. Our 500- and 1000-gallon tanks looked like they were lightproof, but a quick check with the LED light of a cell phone immediately showed otherwise. You can paint translucent surfaces with a high build primer and then several coats of enamel paint until no light passes.

Mitigation mechanisms should be layered—for example, we use inline UV sterilization units at three separate points in our system and cartridge filtration at three other points. Mechanical filtration will work better (and be easier to operate!) if the filter sizes are layered, keeping the smallest filters from plugging with larger material and the system flowing freely.

“

“Water in the system always should be moving. Stagnant water can lead to anoxic conditions and bacterial growth, so it's important to maintain a constant flow of clean water through the system.”

— Dave Bailey

GreenWave, Connecticut



Mechanical filtration

NURSERY INFRASTRUCTURE

Envelope

The envelope refers to the physical structure and features that make up the facility's walls, floor, and access points. This could be a room in a lab or larger facility or a stand-alone structure such as a shipping container. Understanding these elements is crucial for creating the right environment for your kelp cultivation.

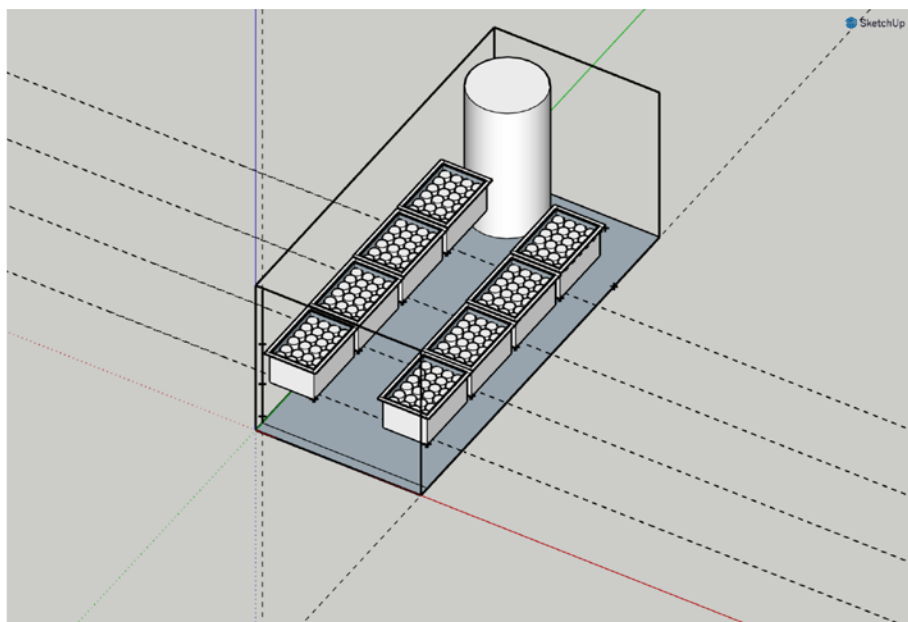

The Structure

Our kelp nursery facility is housed in a 20-foot refrigerated shipping container that had reached the end of its primary use. These containers are a fantastic starting point due to their insulation properties. They come with a robust 1.5-inch foam insulation layer, which helps maintain the right temperature for kelp cultivation. Inside, you'll find a stainless steel liner, which is excellent for durability as well as attaching fixtures and mounting systems, and an aluminum grate floor with a drainage plane and drains in the corners for ready cleaning.

To make it easier to access the container and work inside, we've made a modification. We cut a hole into one end of the container and retrofitted a restaurant cooler door. This modification provides a convenient and user-friendly entrance, making it easier for operators to manage the kelp cultivation process.

NURSERY INFRASTRUCTURE

Cooling System Considerations

The facility comes with a built-in cooling system to regulate the temperature. However, it's worth noting that this cooling system can be quite noisy, which can be a challenge for operators working inside.

Additionally, it requires a three-phase 480-volt, 30-amp power supply, which is not commonly available in all locations. To overcome these challenges, we've implemented a backup cooling solution. We use a step-up transformer that can convert 240-volt three-phase power into the necessary 480-volt power. This ensures that we have a reliable and accessible power source for our cooling needs.



NURSERY INFRASTRUCTURE

Cooling

Our cooling system is designed to control the water temperature in the nursery. The unique thing about this system is that it uses chilled air, allowing us to efficiently manage temperature without the need for extensive piping that can be prone to contamination. When a cooled envelope isn't possible, you can chill your tanks by other means like aquarium chillers. Regardless of the system you are using, be sure to thoroughly clean equipment before use. Some aquarium chillers can be very difficult to clean, so consider pumping bleach through it for at least eight hours.

Key Considerations in System Design

We use a walk-in cooler chilling system with its compressor installed on the exterior of our building. When designing and installing the cooling system, several important factors come into play.

Factor	Recommendation
Power availability	Three-phase is needed to repurpose the integrated cooling system of the container. If you are using remote mechanicals, then single-phase is possible, although you may need access to 220v power.
Insulation of the container	1.5 inches thick
Daily water volume	Our system is designed to handle a 100% daily replenishment of water, which amounts to 520 gallons in our case. If the water is processed at ambient temperature, make a plan to cool it before it enters the grow tanks. We use a 200-gallon tempering tank inside the nursery space.
Frequency of operator access	We assumed for our operators that they will enter the container approximately 6 times per day. We cut an opening at the end of our container and installed a 36-inch door from a food service walk-in cooler to make operator access easier.
Heat load generated by equipment	8 x 60-watt LED panels 8 x 9-watt UV filters 1x 57-watt UV filter 8 x 15-watt tank pumps 8 x 2.5-watt air pumps 1 x 28-watt circulation

NURSERY INFRASTRUCTURE

Lighting

Proper lighting is essential for the growth and health of our kelp, and we've implemented an efficient setup to ensure our kelp gets the illumination it needs.

Our lighting system uses full spectrum LED flat panels that are specifically designed to withstand wet environments.

These panels have a diffuser panel to ensure even light distribution. The various components of our lighting system are:

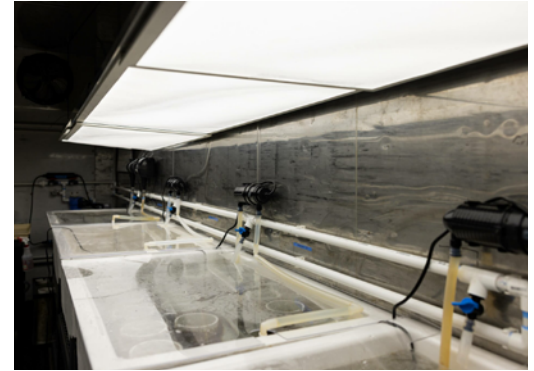

1. **Dimmable Light:** Our system is dimmable, and we've achieved this by retrofitting a 0–10V PWM dimmer into the power supply junction box, which is conveniently mounted to the top of the lights. This dimming capability allows us to adjust the intensity of light needed to create ideal conditions.
2. **Frame:** To support the lights, we've designed a sturdy frame made from 1-inch box aluminum. It includes two lateral crossmembers that help maintain the width of the aluminum, ensuring stability and durability.
3. **Ceiling Suspension:** Our entire lighting array is suspended from the ceiling using a boat hoist. The hoist is attached to the crossmembers of the frame. This setup allows operators to easily lower the lights all the way down to the tank when necessary.

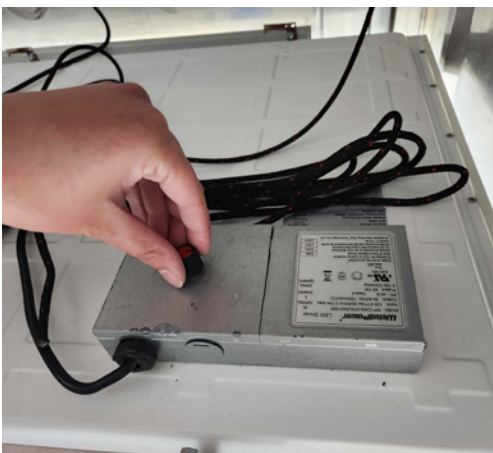

From left to right: Dimmable light, frame, ceiling suspension

NURSERY INFRASTRUCTURE

Grow Tank Setup

Our grow tanks are specially designed reinforced fiberglass tanks with a capacity of 67 gallons. Their interior dimensions are 36 inches wide by 24 inches long by 18 inches deep. Additionally, each tank has a 2-inch rim on all edges, making the overall dimensions 38 inches wide by 26 inches long. The tanks are coated with a pure white gel coat to ensure that any light entering the tank is effectively reflected. A 1-inch thread x thread fitting was cast into the bottom of the tank for the standpipe connection, centered on the 24-inch long wall of the tank.

GreenWave’s grow tank setup includes an air stone, a water circulation manifold with a small pump, a small UV filter, and an acrylic spool stand. These additional features require some fine tuning; cut, prep, and sanitize your materials before it is time to move your seed spools into your tanks. You will need to cut tubing and make frames and stands that will fit your tanks properly.

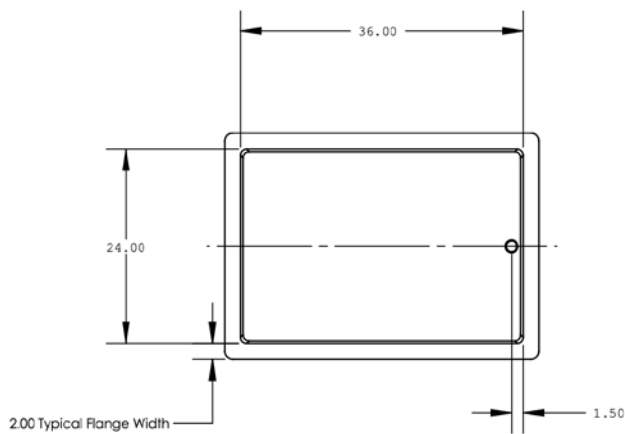

NURSERY INFRASTRUCTURE

The **PEX** frame with holes drilled in it is used to create water flow throughout the tank. GreenWave makes ours from a ¼-inch PEX pipe and **nylon elbows**. We use **flexible silicone tubing** for the line that runs from the air pump to the air stone. We drill ~⅛-inch holes in the PVC that are ~3 inches apart. The pump that is used to circulate the water through the frame and UV filter sits snugly inside one of the spools. Made from ⅛-inch white acrylic, the spool stand features cutouts spaced roughly 1 inch apart to hold the spools. Each grow tank is connected to an individual **air pump**. A **0.5 micron filter** is attached to the pump's inlet, while an **airstone** is connected to **flexible tubing** via the pump's outlet. A **control valve** is installed inline to regulate the flow of air to the air-stone.

For our spool stand, we've used a sheet of **⅛-inch white acrylic**. We've carefully cut out holes in this sheet to hold our spools, making sure they are evenly spaced just 1 inch apart. We used a hole saw and a drill press for this task. Additionally, we've created a special hole for the standpipe drain, which helps maintain water levels in our tanks. To ensure everything fits perfectly, we've spaced the two spools closest to the drain an extra ¼ inch apart to accommodate the drain fitting. And to make sure the acrylic sheet sits flat on the tank bottom without any issues related to the tank's curvature, we've cut the corners at a 45-degree angle.

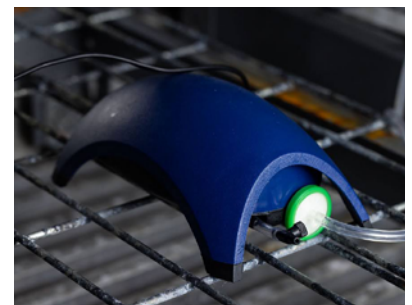
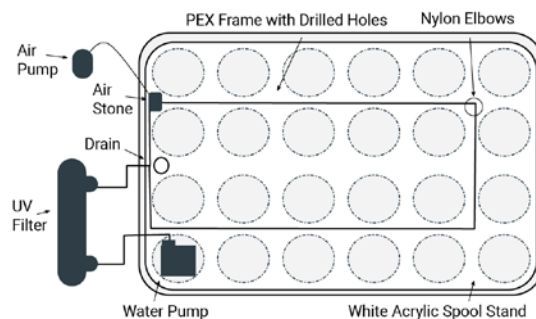
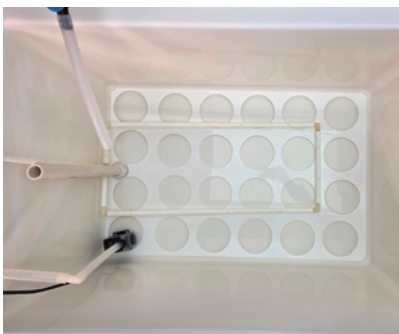

From left to right: Grow tank setup, grow tank components, air pump

NURSERY INFRASTRUCTURE

Grow tank drains are connected to 1-inch valves, enabling individual tank isolation during cleaning. These valves are linked to a 2-inch waste circuit that runs centrally along rows of tank stands and the container's perimeter. The waste circuit includes a standpipe for condensate waste from the air handler and a 3-inch open drain for incidental water disposal. As our system lacks access to a gravity drain, wastewater is collected in a 55-gallon drum. An Eheim pump, controlled by a sump pump waste switch, removes water from the drum to an overhead waste line leading to a drain. This setup allows us to closely monitor water consumption, ensuring it doesn't exceed our water capacity.

Tank racks or supports should be heavy duty to withstand the weight of the full tanks. We find aluminum dunnage racks with box aluminum leg extensions work well for this, but there are many options depending on the desired height and size of your tanks. Keep in mind that if your tanks are too low, it may increase the chance of items falling into them, increasing the possibility for contamination. If the tanks are too high, they may be difficult to tend to.

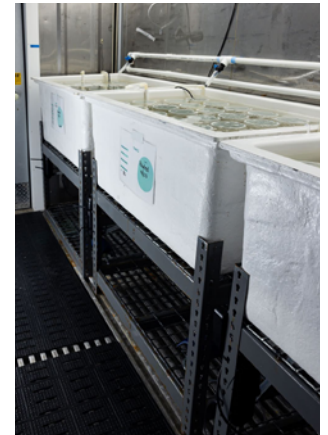

*Left: Valve
Right: Tank racks*

PART 03

PRE-SEEDING PREPARATION



PRE-SEEDING PREPARATION

There is a significant amount of preparation that goes into getting seed spools ready for seeding, including cutting spools, wrapping spools, leaching seed-string, and rinsing spools. This preparation should be completed well before it is time for you to start seeding. Winding spools can take up to 1 hour per spool without a spool winding device, so plan accordingly.

Cutting and Sanitizing Spools

If you are a new nursery, you may have to cut new spools before your season. Each nursery may fashion its spools a little bit differently, but the principle is the same. It is best to use PVC that is no more than 20 inches long. A spool longer than that may be difficult to use during seeding because the seedstring will not unwind effectively as you pull the spool down the line. A spool that is too short is an inefficient use of space in your nursery system. Nurseries that ship spools prefer to use thin-wall PVC, typically drainage pipe that is not pressure rated, because of the reduced weight. Nurseries that provide to local farmers typically opt to use normal PVC, which is pressure rated and thicker walled, because it is more robust and durable.

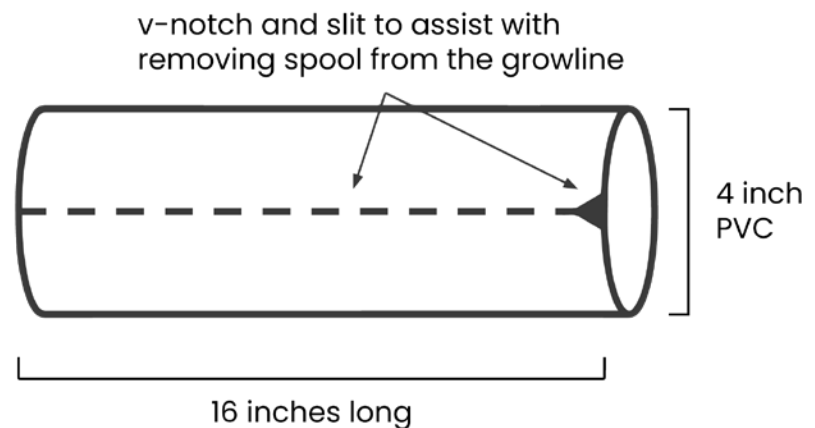

Watch video: [Cutting slit in spool](#)

[The spool cutting jig makes cutting slits safer.](#)

GreenWave uses 4-inch PVC cut into 16-inch lengths. A notch and slit are added so the spool can be pulled off the line after seeding without detensioning the growline a second time. Each of these spools holds ~400 feet of seed-string. If you are cutting a slit in your spools, it's best to make a jig for safety and consistency.

PRE-SEEDING PREPARATION



GreenWave uses this spool cutting jig to keep our cuts consistent.

When you buy PVC, it will be dirty from the manufacturing and shipping process. Additionally, during the cutting process, PVC sawdust will be created and will be stuck to your spools. You will need to scrub and bleach your spools before winding them. To avoid letting sawdust go down the drain, dip your spools in a water bath before washing.



Place washers in the spool slit to prop it open during cleaning and sterilization.

PRE-SEEDING PREPARATION

Protocol for Sanitizing Spools

1. Gather supplies:
 - Tank for soaking
 - Cut, unwound seed spools
 - Sodium hypochlorite (or bleach without any added chemicals)
 - Aquarium pump
 - Freshwater
 - Spool storage bin
 - Paper towels
2. If your spools were just cut, dip them in a water bath to rinse off the PVC particle dust.
 - Try to avoid washing the PVC sawdust down the drain. You can filter it out of the bath with cheesecloth or a small aquarium net.
3. Scrub your spools and rinse them with freshwater.
 - Make sure you scrub all parts of the spool including the inside, top and bottom rims, and the edges of the v-notch.
4. Place a washer or similar spacer in the top and bottom of the slit on each spool to hold it open during bleaching.
 - The washers ensure that the bleach touches every part of your spool. Bleach is only effective through contact.
5. Prepare a tank and a small aquarium pump for soaking your spools.
 - Clean the tank and pump of any dust or other particles.
 - Circulate water in the tank with the small aquarium pump during the entire sanitizing process.
6. Fill the tank with enough freshwater to cover your spools.
7. Add bleach to your tank to exceed 500 ppm and let the bleach circulate.
 - Use 10 mL of household bleach per 1 L of water, or 3 tablespoons per 1 gallon.
 - Check the concentration using [chlorine test strips](#).

PRE-SEEDING PREPARATION

8. Add your spools to the water and let them soak for at least 20 hours.
 9. Add sodium thiosulfate to neutralize the bleach in the water in your tank.
 - Approximately 1–2 grams of sodium thiosulfate will be required or to neutralize 1 gallon of a 500 ppm chlorine solution.
 - Always use a test strip to check that the chlorine is neutralized after you add and stir in the sodium thiosulfate.
 10. Let the spools soak in the neutralized water for at least 1 hour.
 11. Remove the spools from the tank and leave them in a clean space to dry.
 - Place the spools on a clean surface in an area away from contamination sources, including running seawater.
 - Dust and contaminants in the air can stick to the wet spools and cause contamination issues in your nursery later on.
 12. Once the spools have dried, store them in an airtight cabinet or bin that has been wiped down with ethanol.
 - Line the cabinet or container with clean paper towels to make sure the spools do not come in direct contact with the bottom or walls.
 13. Keep the spools in a dry place until winding.
 - Use silica beads as a desiccant, if necessary, to keep the storage space dry.
-

PRE-SEEDING PREPARATION

Winding and Soaking Spools

Consider making a spool winding device/machine to speed up the winding process. Other nurseries have used anything from a hand drill and a paint roller to a sophisticated automated design. You want the spool to turn quickly and with as little friction as possible.

Maintain cleanliness while winding your spools. All spools, whether new or used, should be scrubbed and bleached before winding. Always handle the seedstring and spools with gloves to maintain best biosafety practices and minimize contamination.

While you are winding your spools, be on the lookout for a few main factors as quality control: no gaps between wraps, no overlapping wraps, and tight wraps. Gaps between wraps will result in inconsistent lengths of seedstring on your spools. Overlapping wraps can cause issues when seeding your lines on your farm by creating snags or loops. Loose wraps can result in seedstring sliding off of spools in the nursery, during transport, or seeding, as the seedstring will loosen up a little once it is wet. All of these issues can significantly impact your spool quality. Always wrap the seedstring around your spools in the clockwise direction, if looking down at your spool from the top, so that your seedstring will wrap around your growline in the same direction as the lay of the growline. Pull the ends of your seedstring through the slit to keep it tight. It may also be helpful to tie a bowline or other loop knot at the end of your seedstring so you can use it to pull on when you are seeding in the field. Once a spool is wound, give it a unique ID like a number for tracking during the season.

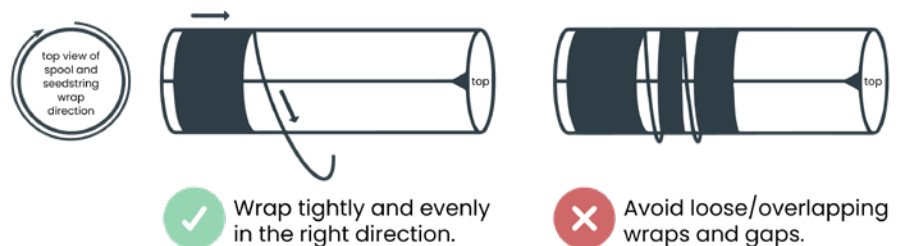

PRE-SEEDING PREPARATION

GreenWave suggests using [Holdfast](#) seedstring for spore seeding and Hortimare's special-made seedstring from [Langman](#) for gametophyte seeding. Order your seedstring early in the calendar year to ensure you receive your order in time for the start of the nursery season. Other nurseries have had luck using other seedstring types in the past; to learn more about this, you can search the [Hub Community page](#) for previous posts, or post a question yourself. Regardless of the seedstring you use, it is important to find out as much as you can about the manufacturing process and what chemicals the string may have come in contact with. As a precaution, soak all seedstring after it is wound onto seed spools but before seeding to allow any excess chemicals to leach out. Soaking entire spools of fresh string before they are wrapped on seed spools is not sufficient because the inner wraps will not be exposed to water.

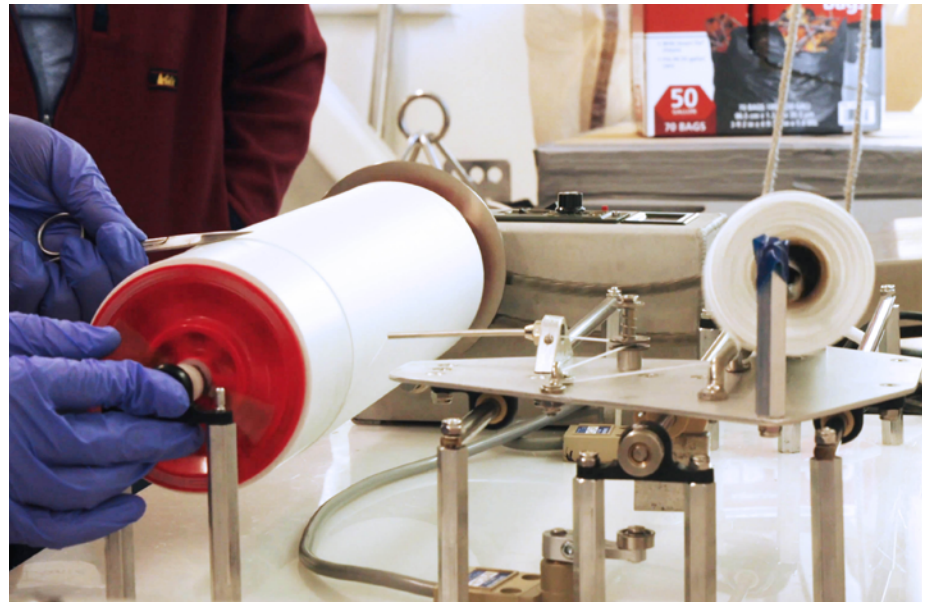

Watch video: [Spoolerator demonstration](#)

GreenWave uses a mechanical device called a spoolerator, designed to quickly and efficiently wrap spools with seed string.

PRE-SEEDING PREPARATION

Protocol for Soaking Spools

1. Gather supplies:

- Ethanol spray bottle
- Tank for leaching
- Wound seed spools
- Sodium hypochlorite (or bleach without any added chemicals)
- Aquarium pump
- Freshwater
- Saltwater
- Spool storage bin
- Paper towels

2. Prepare a tank and a small aquarium pump for soaking your wound spools.

3. Clean and bleach the tank and pump.

- Bleach the tank for a minimum of 2 hours using tap water.
- Add bleach to your tank to exceed 500 ppm. You can test this using chlorine test strips.
- Circulate the water in the tank with the small aquarium pump during the entire sanitizing and leaching process.

4. Neutralize the bleach in the water in your tank with sodium thiosulfate.

- Approximately 4 grams of sodium thiosulfate will be required to neutralize 1 gallon of a 500 ppm chlorine solution.
- Always use a test strip to check that the chlorine is neutralized after you add and stir in the sodium thiosulfate.

5. Place your wound seed spools in the tank with the neutralized tap water and let them soak for 24–48 hours.



Note: This protocol combines the process of bleaching a grow tank and leaching wound spools to save water. If preferred, these two tasks can be done separately as long as you ensure the spools are only leached in clean water. The wound spools should never be soaked in bleach water before it has been neutralized.

PRE-SEEDING PREPARATION

6. Monitor the water for cloudiness.
 - If the water gets cloudy quickly within the first 24 hours, dump the cloudy water and restart the process with step #2.
 7. After 24–48 hours, if the water still looks clear, remove the spools from the water and place them in a clean area while you drain the tank.
 8. Wipe the tank down with ethanol, and rinse it with sterilized seawater.
 9. After rinsing, fill the tank with sterilized seawater and soak the spools for a second time for 24 hours.
 10. After soaking, remove the spools from the tank and leave them in a clean space to dry.
 - Place the spools on a clean surface in an area away from contamination sources, including running seawater.
 - Dust and contaminants in the air can stick to the wet spools and cause contamination issues in your nursery later on.
 11. Once the spools have dried, store them in an airtight cabinet or bin that has been wiped down with ethanol.
 - Line the cabinet or container with clean paper towels to make sure the spools do not come in direct contact with the bottom or walls.
 12. Keep the spools in a dry place until use.
 - Use desiccant if necessary.
-

PRE-SEEDING PREPARATION

Tank and Water System Cleaning

Tank and water system cleaning is an essential process for running a successful nursery. This process looks slightly different for each facility. Clean your tanks and system once at the end of your season and again just before the new season is starting up. Contaminants in your tanks, pumps, pipes, tubing, etc. can all cause failure later on during your nursery season. Always think about your nursery as a whole system when deciding how to approach cleaning; one dirty pipe at the beginning of your system will cause contamination in other components down the line. Likewise, using the same tools to scrub a part of your system that only comes in contact with sterilized water that you used for cleaning a dirty part of your system without sanitizing the brushes between is bad practice. Thoroughly scrub and clean anything that could have biofilm or collect contaminants. Sterilize with a bleach solution that exceeds 500 ppm and use 1–2 grams of sodium thiosulfate per 1 gallon of bleach water that is 500 ppm to neutralize the chlorine. The general cleaning process is as follows:



There are a few main rules GreenWave recommends you follow when cleaning your tanks and nursery system:

1. Get eyes on every nook and cranny during cleaning.
2. Scrub everything to remove any biofilm buildup.
3. Clean the “clean” parts of your system first.
4. Sterilize your brushes/cleaning gear between moving to different parts of your system. (Refer to the [GreenWave System and Nursery diagram](#))
5. Run bleach through your system where possible.
6. Flush/rinse your system with sterile seawater after you finish cleaning and before you begin using it.
7. Replace filters frequently, especially at the beginning of a new season or directly after cleaning.

PRE-SEEDING PREPARATION

In order to fulfill rule #1, GreenWave avoids using PVC glue or piping that is too long for a scrub brush to reach. Instead, all of the piping in the nursery is connected by wrapping the end of pipes with Teflon tape and pressing the pipe into the sockets of fittings. An exception for this is in areas that experience high pressure or where a failure would be catastrophic, like around pumps or on the bottom of water holding tanks. In these cases, we use unions to segment glued sections into lengths of 3 feet or less to facilitate through cleaning.



The darker, compressed Teflon (left) is a good signal that the Teflon was applied correctly. Avoid bunching too much Teflon in the end of the pipe (middle). If you see a significant amount of bunching after putting the pipe in the fitting (right), take it apart and redo the Teflon.

If you have many people working in your nursery in a given season, you need to put systems in place for recording activities. Make sure everyone is very clear on sterile procedures and the water filtration system. A rough diagram of the [GreenWave water system and nursery](#) can be found in the resources section; make a similar diagram of your system for nursery managers to reference.

PART 04

MAKING MEDIA AND OTHER SOLUTIONS



MAKING MEDIA AND OTHER SOLUTIONS

Media can be made using many different methods. The most important nutrients for kelp are nitrogen and phosphorus, but other micronutrients and vitamins play essential roles in the biological processes of kelp too. The easiest way to make media is using a premixed **F/2 powder** that is simply mixed into sterile seawater and filtered. The appropriate dosage of nutrients depends on the life stage of the kelp (see **Environmental Conditions Chart**). When keeping gametophytes, the nutrient dosage is much higher than when keeping seed spools, and the dosage for seed spools may change during their time in the nursery. Other nutrient mixes that have been used to culture kelp are **Proline F/2 Algae Food** and Provasoli's Enriched Seawater (PES). These recipes can be found online, but they are typically more expensive and difficult to make.

Other culturing solutions may be used to treat certain types of contamination (e.g. bacteria and diatom outbreaks). Like nutrient dosing, the dosing of these solutions is different for tanks and cultures. Although these solutions can treat contamination outbreaks, it is best practice to follow the proper steps to avoid contamination in the first place. Making and using the solutions is costly and adds labor to your operation.

“

“We use Jack’s Professional fertilizer with a 25-5-15 NPK ratio because it closely mimics the nutrient profile of Provasoli’s Enriched Seawater with Iodine (PES). It comes in pellet form, dissolves cleanly in water, and is very cost-effective—about 10 times cheaper than other options.”

— Tamsen Peeples

University of Alaska Fairbanks,
Alaska



Media preparation equipment.

MAKING MEDIA AND OTHER SOLUTIONS

Protocol for Preparing Solutions

1. Ensure your work area is clean and sterilize any surfaces that will be used with a generous amount of ethanol.
2. Gather supplies:
 - Gloves
 - Ethanol spray bottle
 - Paper towels or kimwipes
 - Permanent marker
 - Scooper
 - Stir bar
 - Vessel for mixing
 - Smaller storage vessels like falcon tubes
 - Stir plate
 - Microscale
 - Weigh boat/weigh paper
 - Sterile seawater or DI water
 - Graduated cylinder
 - Chemicals
3. Ensure all supplies are sterile. (*This is essential when preparing stock solutions. Contamination in the stock will likely result in contamination issues in tanks/cultures before you know it is in the stock, as well as result in wasted chemicals.*)
4. Use the [Media and Solutions](#) chart to plan out the volume of stock you will need to make based on the number of tanks/cultures you will be dosing.
5. Measure and pour the sterile seawater or DI water, as indicated in the [Media and Solutions](#) chart table, into the mixing vessel.
6. Sterilize the stir bar using ethanol and a wipe, let the ethanol evaporate, and add it to the mixing vessel.
7. Turn on the stir plate to a speed fast enough to generate a funnel in the water.

MAKING MEDIA AND OTHER SOLUTIONS

8. Turn the microscale on and add the weigh boat.
 9. Zero the scale.
 10. Using a scooper, carefully weigh out the chemicals needed based on the “Concentration of Stock” column on the [Media and Solutions](#) chart.
 - Weigh the chemicals in small increments because excess chemicals that have been removed from the original container must be thrown away, not returned to the container. Otherwise, you risk contaminating your whole bottle of chemicals.
 11. Pour the weighed chemical into the mixing vessel a little bit at a time. (Avoid adding all the chemicals at once, as it may create clumps that will take longer to dissolve.)
 12. Wipe up any spilled chemicals from your work area.
 13. Allow the solution to stir until everything is dissolved.
 - You may need to reduce the stir speed to clearly see if everything is dissolved.
 14. Pour the solution into smaller storage containers.
 - Use smaller containers to avoid opening the main stock container every time you use it. Opening the stock container frequently increases the chances of contamination.
 15. Label small containers with the date, chemical, concentration, and your initials.
 16. Store the solution according to the [Media and Solutions](#) chart.
 17. Dose cultures and tanks with the stock solution according to the respective “Concentration in Cultures” and “Concentration in Tanks” columns on the [Media and Solutions](#) chart.
-

PART 05

SOURCING SORUS MATERIAL



SOURCING SORUS MATERIAL

For sugar kelp, sorus material is the dark strip that forms on the kelp blade during fall and spring. For other species, sorus forms on other parts of the plant and may look different. Reference the [Species Identification lesson](#) on the Hub for a more detailed breakdown. Some kelps have phenotypic plasticity, meaning the appearance or shape of the kelp looks different depending on the environment it is growing in. This is seen in sugar kelp in some regions where certain locations have skinny kelp and others have normal kelp. Keep in mind that the morphology of the wild kelp you source can influence what your kelp will look like on your farm. Sorus formation in the wild is triggered by changes in temperature and light intensity and duration. When sourcing sorus material for seeding spools or creating cultures, it is important to source material that is relatively clean and free of fouling. Epiphytes from the blades can cause major contamination outbreaks during seed spool rearing and in gametophyte cultures.

The exact timing of sorus formation depends on the kelp bed and the water conditions. Normally, sorus will start to develop as temperature, light intensity, and the number of hours of daylight all begin to drop. Each kelp bed is different, and you may have to check the bed multiple times before finding ripe sorus. You begin to see sugar kelp sorus on the East Coast in October. If you don't know where kelp beds are near your farm, you can use a marine chart to help you narrow down potential locations. In Alaska, sugar kelp tends to prefer muddy or sandy bottom types, whereas *Alaria* and bull kelp like more exposed locations with stronger wave action. On the East Coast, sugar kelp can be found in rocky-bottomed areas. You may also want to reference available public resources of detailed kelp forest surveys, like [ShoreZone](#).



Left: Sugar kelp (*Saccharina latissima*) sorus tissue
Right: Bull kelp (*Nereocystis luetkeana*) sorus tissue

SOURCING SORUS MATERIAL

Follow these guidelines for responsible sorus collection:

1. Source sorus material from kelp beds within the region where you are growing your kelp.
2. Only source sorus from kelp beds that are abundant.
3. Never take all of the fertile blades from one bed. If a bed is sparse, don't take more than 10% of the available sorus. You can also avoid taking the entire fertile section of a blade.
4. If a kelp bed looks like it has experienced significant dieback or has little to no sorus, consider collecting from a different bed.
5. For sugar kelp, leave the holdfast and meristem attached and only take the top portion of the blade. For other species, only take the fertile portion of the blades or sporophylls.
6. Target blades that have little to no biofouling.

You can collect your sorus by snorkeling, diving, or wading in at low tide. The conditions at the site you choose will determine which method will work best. Review your state's regulations around sorus collection before you collect, as some jurisdictions require a permit for sorus collection. For example, there are multiple regulations in Alaska concerning sorus collection. The "50-50 rule" requires that sorus tissue collected for mariculture must come from at least 50 parent individuals located within 50 kilometers of the outplanting site to protect genetic diversity in kelp populations. Additionally, Alaskan nursery operators are required to apply for a [Stock Acquisition and Transport Permit](#). Even if farmers will be doing the sorus collection, the receiving entity is re-



SOURCING SORUS MATERIAL

responsible for securing the permit. No matter where you operate, if farmers are collecting their own sorus and sending it to you for seeding, make sure they are familiar with best practices for collecting, packaging, and shipping sorus ahead of time.

Once you've collected ripe sorus material, you will have to transport or ship the sorus to the facility that will be processing it. Keep the blades chilled and damp during transport and shipping. This can be achieved by packing the blades with paper towels dampened with seawater and ice packs. In Alaska, some nursery operators prefer dry or slightly dampened paper towels for bull kelp, as damp towels can make the blades mushy, reducing sorus quality. Make sure the blades won't come in contact with any freshwater, including condensation that may form around the ice packs; it can cause spoiling or blistering. When possible, choose the quickest available shipping option. In Alaska, the preferred method is Alaska Airlines GoldStreak, while in other regions, FedEx or UPS may be more practical. Whatever carrier you use, it is important to do your own due diligence to ensure reliable, timely delivery of materials. The blades can be in a properly packed box for up to three days without spoiling. Prepare the sorus no more than 72 hours after the blades are harvested. Complete your sorus release between 18 and 24 hours after processing.



A "kelp burrito" can be an effective way to transport sorus tissue.

SOURCING SORUS MATERIAL

Protocol for Packaging and Shipping Sorus Tissue

After you've found a collection location and window for sorus, prepare your collection/shipping tool kit.

1. Gather supplies:

- Cooler or other insulated container (styrofoam box, cooler bag, lunch box, etc.)
 - One cooler for each collection location
- Large ice packs that will stay frozen for the entire shipping process
- Spacing material (cardboard, foam, bubble wrap, etc.)
- Paper towels
- Clean seawater
- Sharpie
- Labeling tape
- Cardboard box
 - Some shipping services will require you to pack your insulated container inside a cardboard box for shipping.

2. Inspect the collected blades. If they are heavily fouled with epiphytes that cannot be rinsed off, do not use them.

- Snails or other animals can be rinsed off. Do not use blades with bryozoans or hydroids, which cannot be rinsed off.

3. Trim the blade to remove the holdfast and parts of the meristem with no sorus tissue. If a blade is very wide, consider trimming the edges for easier packing.

4. Prepare your cooler. Pack sorus from separate collection locations in different coolers.

- Put a piece of labeling tape on the cooler with the collection location, date, and collector name.
- Place the ice packs at the bottom of your cooler. It is important for the ice packs to be on the bottom so the condensation does not drip onto the kelp and damage the blades.
- Cover the ice packs with spacing material to prevent the kelp from coming in direct contact with the ice packs.

SOURCING SORUS MATERIAL

5. On a clean, dry surface, roll out your paper towels and place the sorus on the sheet.
6. Roll up your sorus in the paper towels.
7. Soak each roll in clean seawater, then place them in the cooler.
 - Do not pack the rolls too tightly, they need to have space between them so they can breathe.

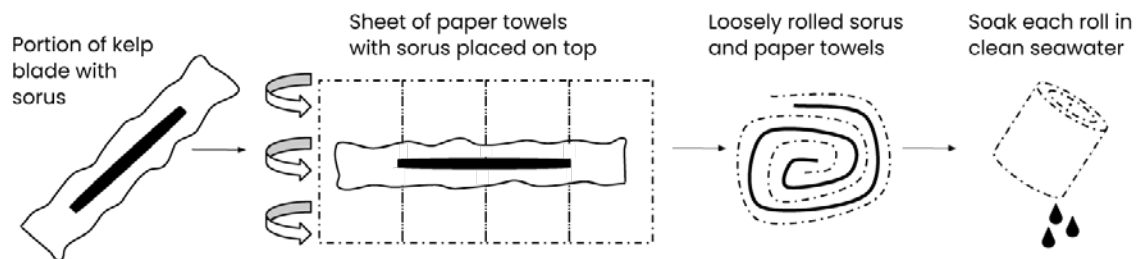

8. Fill any empty space in the cooler with extra packing material, just enough to prevent the rolls from unraveling during transport.
9. Close and seal the cooler.
10. Mark the box with “this side up” and an arrow indicating the top of the box.
11. Send the shipment with a reliable service with the quickest shipping option.
 - Make sure that the recipient of the package will be present to receive the shipment and is able to process the sorus upon receipt.
 - Typically, we avoid sending packages on Thursdays and Fridays because if a package is delivered late or sits outside too long, the sorus may spoil.
12. Check the tracking of the package frequently and forward the tracking information to the recipient.



Sori-box filled with *Saccharina latissima* rolled in tissue and soaked in sea water, ready for shipment.

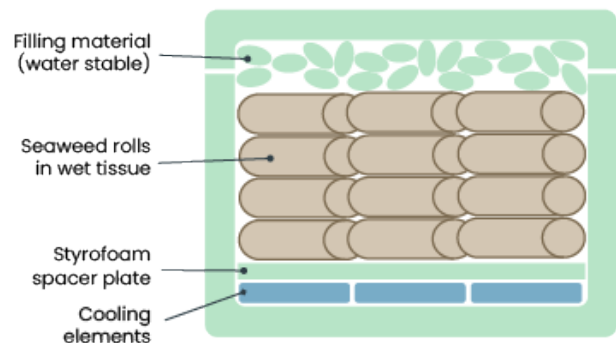

Schematic of Sori shipment box build-up

PART 06

SORUS PROCESSING



SORUS PROCESSING

“

“To keep sorus processing quick and efficient, we use two unique tools: a salad spinner to dry our sorus tissue and a DIY light board (a cutting board with a light source underneath) that helps make epiphytes on the sorus tissue pop, which allows us to easily spot and remove them.”

— **Cara Blaine**

Atlantic Sea Farms, Maine

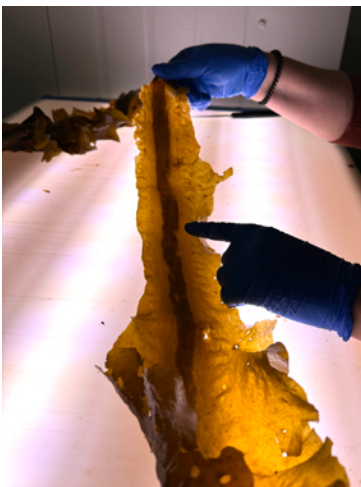

Image courtesy of Atlantic Sea Farms

After the sorus is collected and brought back to your facility, you can prepare the material and do a sorus release by cutting the reproductive material away from the rest of the blade and cleaning it. Blade material brought in from the wild presents a contamination vector for the rest of your nursery operations. Carefully clean the blades in an area of your facility that is easy to clean and separate from other cultures. Different kelp species may have different needs for optimal release. For example, bull kelp can be particularly sensitive and may release spores early if the sorus tissue is handled too vigorously. Because all species behave differently, it is important to start with a known protocol, like the one outlined here, and make small iterative changes until you find what works best. There have been many published methods of cleaning sorus material; below, we chose the method that we find most effective for sugar kelp in our facility.

Sorus tissue is ready to be released on the day after sorus preparation. Generally, the sorus preparation, release, and seeding will take a whole afternoon and will be completed much faster with extra sets of hands.



SORUS PROCESSING

Protocol for Processing Sorus Tissue

Ensure your work area is clean and sterilize any surfaces that will be used with a generous amount of ethanol.

1. Gather supplies:

- Gloves
- Ethanol spray bottle
- Absorbent paper towels or kimwipes
- Permanent marker
- Razor blades or scissors
- Small beakers (100–200 mL)
- Sterilized seawater
- 0.15% sodium hypochlorite solution
 - For other cleaning in the nursery, you can use household bleach with no added chemicals, but use sodium hypochlorite instead of household bleach when handling live material.
- Cotton balls or soft sponge pieces
- Cutting board
- Tweezers

2. Ensure all supplies and the working surface are clean.

3. Start by preparing your media and bleach solution.

- You will need about 200 mL of seawater and 75 mL of 0.15% sodium hypochlorite solution per blade you are processing.
- Since the sodium hypochlorite (NaOCl) solution is volatile, prepare it in small batches and use immediately.

4. On a clean surface outside of the hood, begin cutting out the sorus from the blade with scissors or a razor blade. The washers ensure that the bleach touches every part of your spool. Bleach is only effective through contact.

- Only handle one blade at a time to avoid cross contamination.
- Cut away all pieces of the blade that are not sorus.
- Do not keep any pieces of the sorus that look like they have epiphytes or are otherwise fouled.

5. Dip a cotton ball, clean paper towel, or small piece of soft sponge into sterilized seawater to dampen it. Squeeze out the excess water.

6. Gently wipe the surface of the sorus with the sponge.

SORUS PROCESSING

7. Place the wiped sorus into a labeled beaker and move to a chilled area if you are processing many individuals.
 8. Once all of your sorus is cut from the blades and wiped clean, you will begin the rinsing process under a hood or on a separate cleaned surface.
 - From here on, handle the sorus with clean tweezers, not by hand.
 9. Pour enough 0.15% NaOCl solution into the beaker to cover the sorus and swirl frequently.
 10. After 1 minute, pour the bleach solution out. Be careful to not dump any sorus material by holding it back with tweezers.
 11. Pour sterilized seawater over the sorus until it is submerged and swirl frequently.
 12. After 2 minutes, pour the sterilized seawater out.
 13. Rinse with sterilized seawater a second time.
 14. After 1 minute, pour the sterilized seawater out.
 15. Use the tweezers to transfer the sorus to a paper towel.
 16. Use the paper towels to gently dab the sorus until it is dry enough to have a matte appearance.
 - Do not rub the sorus.
 17. Move the dabbed sorus to a new paper towel and arrange it in a single layer.
 18. Cover the sorus with another paper towel and label the paper towel with the blade number and location.
 19. Move the dried sorus wrapped in paper towels to a sealable container or plastic bag.
 - Do not completely seal the bag or container to allow air to vent.
 20. Sorus from multiple plants can be stacked on top of one another in the same container as long as there are 2 layers of paper towel between them.
 21. Sterilize the tweezers and begin this process for the next blade.
 22. Do not store material out of the cold for more than 30 minutes.
 23. Once all of the blades are processed, move the container to a cold, dark place for 16 to 24 hours before the release.
-

PART 07

SEEDING SPOOLS

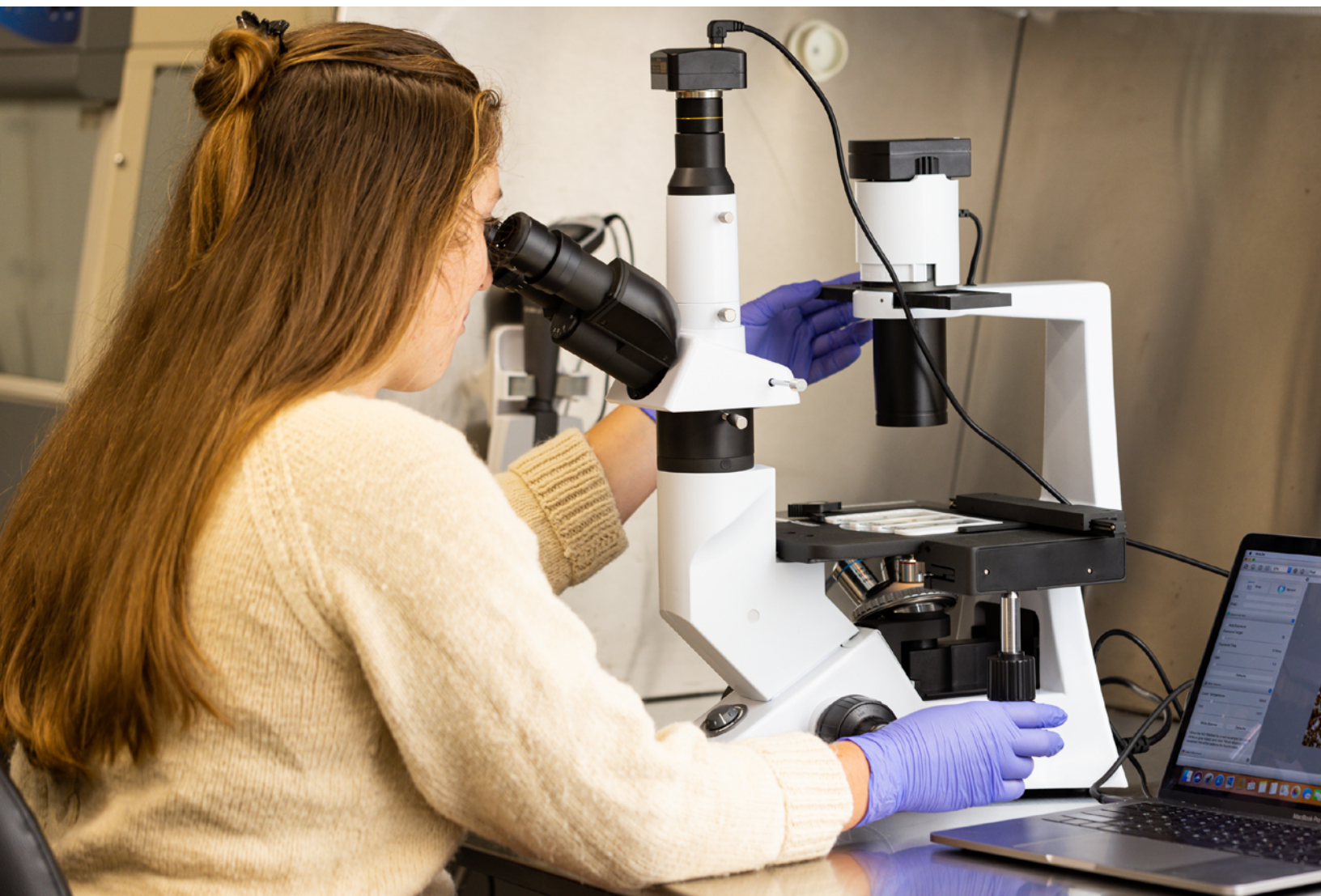

SEEDING SPOOLS

Once your sorus is releasing, you will be able to begin seeding spools. Keep in mind, there is a significant amount of preparation that goes into getting seed spools ready for seeding, including cutting spools, wrapping spools, leaching seedstring, rinsing spools, and cleaning your tank/system. Complete this preparation well before it is time for you to start seeding.

When you are ready to seed, submerge in or rinse your spools with chilled, sterilized seawater so they have time to absorb water. There are many ways to inoculate your spools, and the best way for your facility will depend on the size of your spools, the number of spools you want to inoculate at once, and the tanks you have available. Generally, aim to have as little empty space in your inoculation vessel as possible without your spools touching. Spore seeding is based on volume of water, so empty space in the water column means you need a higher number of spores in your release to seed a bigger tank with fewer spools in it. In the diagram below, less gray space is better. Seeding tubes are another option for seeding; they are a very efficient way to seed, but take more materials and labor to prepare. Regardless of your seeding container choice, you will need to know the total volume of water in the container to do the seeding calculations.

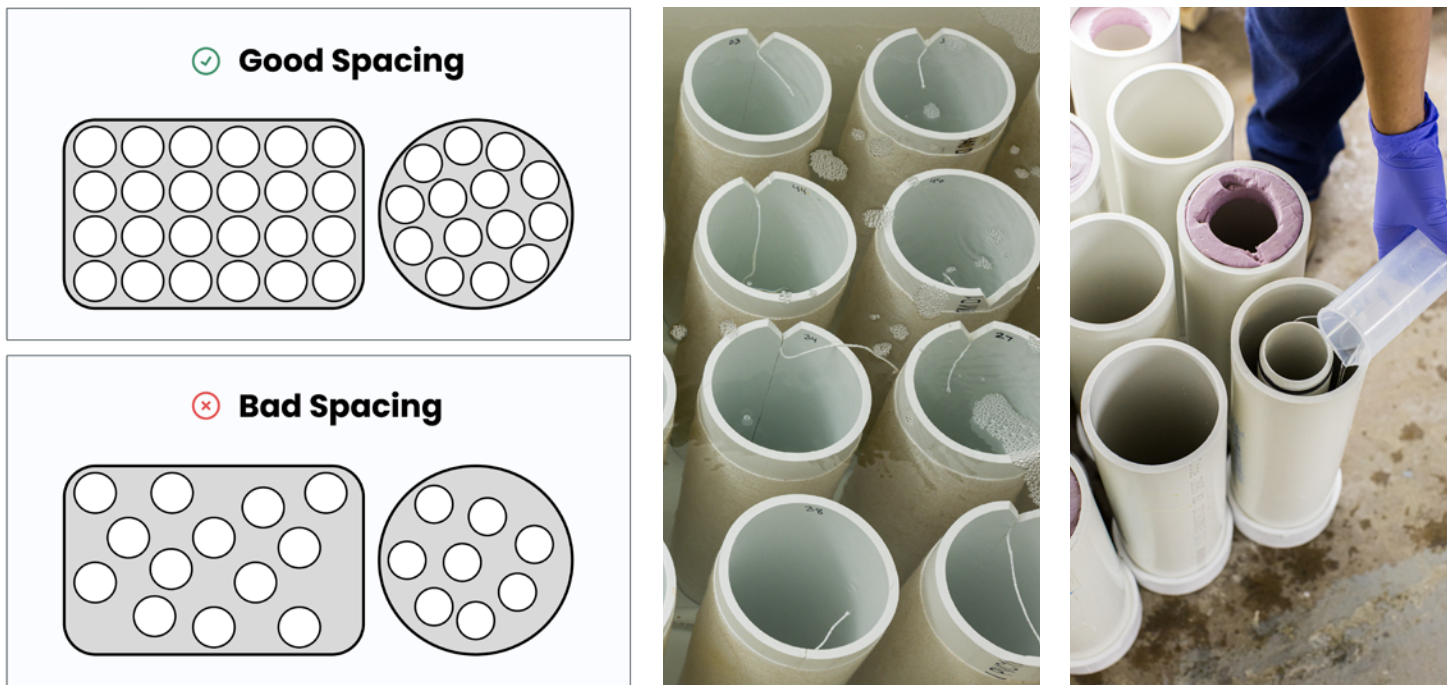

From left to right: Comparison of good and bad spool spacing, well-spaced spools, seeding tube

SEEDING SPOOLS

Protocol for Seeding Spools

Ensure your work area is clean and sterilize any surfaces that will be used with a generous amount of ethanol.

1. Gather supplies:

- | | | | |
|--------------------------|--------------------------|--------------------------|---------------------------------------|
| <input type="checkbox"/> | Gloves | <input type="checkbox"/> | Kanamycin |
| <input type="checkbox"/> | Ethanol spray bottle | <input type="checkbox"/> | Germanium dioxide (GeO ₂) |
| <input type="checkbox"/> | Paper towels or kimwipes | <input type="checkbox"/> | Spools and release tank |
| <input type="checkbox"/> | Spool log sheet | <input type="checkbox"/> | Microscope |
| <input type="checkbox"/> | Pasteur pipettes | <input type="checkbox"/> | <u>Hemocytometer</u> |
| <input type="checkbox"/> | Pasteurized seawater | <input type="checkbox"/> | Cell counter |
| <input type="checkbox"/> | Media vessel | <input type="checkbox"/> | Tweezers |
| <input type="checkbox"/> | Release beaker/bucket x2 | <input type="checkbox"/> | 20–40 um sieve |
| <input type="checkbox"/> | F/2 | <input type="checkbox"/> | <u>Spore Density Calculator</u> |

2. Ensure all supplies and the working surface are clean.

3. Prepare release media with F/2, kanamycin, and GeO₂ according to the Media and Solutions chart and media preparation protocols.

4. Set up the Spore Density Calculator sheet to meet your requirements.

- Choose your stocking density. GreenWave uses 2500 spores/mL for sugar kelp.
- Adjust the Volume of Inoculation Vessel cell to match the amount of liquid (in mL) that will be in one of your inoculation tanks.

5. Place the prepared sorus into a beaker with a label denoting blade number and location.

6. Pour the release media into the beaker until it covers the sorus.

7. Let the beaker sit, swirling occasionally, and monitor for color change in the water.

- Typically, there will be a color change when the sorus releases. The darker the release water, the more spores.
- Keep the temperature of the water as close to 12°C as possible.

8. After a piece of sorus has released, pour the release water through a 20–40 um sieve into a clean release container.

9. Note the volume of release water (in mL) in the Volume of Spore Solution cell.

10. Using a pipette, sample the release water and load the hemocytometer.

- Place a coverslip over the base.
- Hold the pipette close to the valley in the glass.
- Squeeze gently so a drop of the release water is at the end of the pipette.
- Move the drop up to the valley until the capillary action fills the hemocytometer.

SEEDING SPOOLS

11. Under the microscope, begin counting the number of swimming spores seen in the large corner squares.
 - Use the Instructions tab in the Spool Density Calculator sheet for directions on loading and using the hemocytometer.
 12. Count 2–4 of the squares and average the numbers.
 13. Input the average into the # of Spores Counted on the Hemocytometer cell in the Spore Density Calculator.
 14. Look at the two large green cells in the Spore Density Calculator to see how much spore solution you need per inoculation vessel and how many inoculation vessels you can seed with this release.
 15. Use a graduated cylinder to measure out the amount of spore solution indicated in the Volume of Spore Solution Needed to Inoculate row.
 16. Pour the spore solution into the inoculation vessel.
 - For seeding tubes, place the seed spool in the tube. Fill the tube halfway with chilled, sterile seawater. Then, pour the solution around the outside seed spool, avoiding the inside of the spool. Top off the seeding tube with chilled, sterile water to mix the spore solution around in the water column. Cap the tube and store it in a cool place.
 - For seeding tanks, arrange your seed spools in the tank efficiently. Fill the tank halfway with chilled, sterile seawater. Pour the spore solution into the tank around the spools in an evenly dispersed pattern. Use a clean pipe or pump to stir the tank and begin filling the tank the rest of the way.
 - If you don't have pre-chilled water and have to fill your tank ahead of time to chill, pour the solution through a PVC pipe into the tank so that the spore solution gets dispersed throughout the water column or have the aquarium pump running while you pour the spore solution in.
 - If you use chillers and pumps to cool your water, chill your tank room as low as possible and turn the chillers/pumps off for this process.
 17. Leave the newly seeded spools in the dark at 10°C for 24 hours.
 18. After the 24 hour settling period, move the spools into their assigned tanks.
 19. Add nutrient media to the tanks.
 20. Turn on the lights to low-light conditions (20 μmol).
 21. Set up/turn on any other tank equipment that you use, like water flow, aeration, or UV.
-

PART 08

CARING FOR SPOOLS IN THE NURSERY

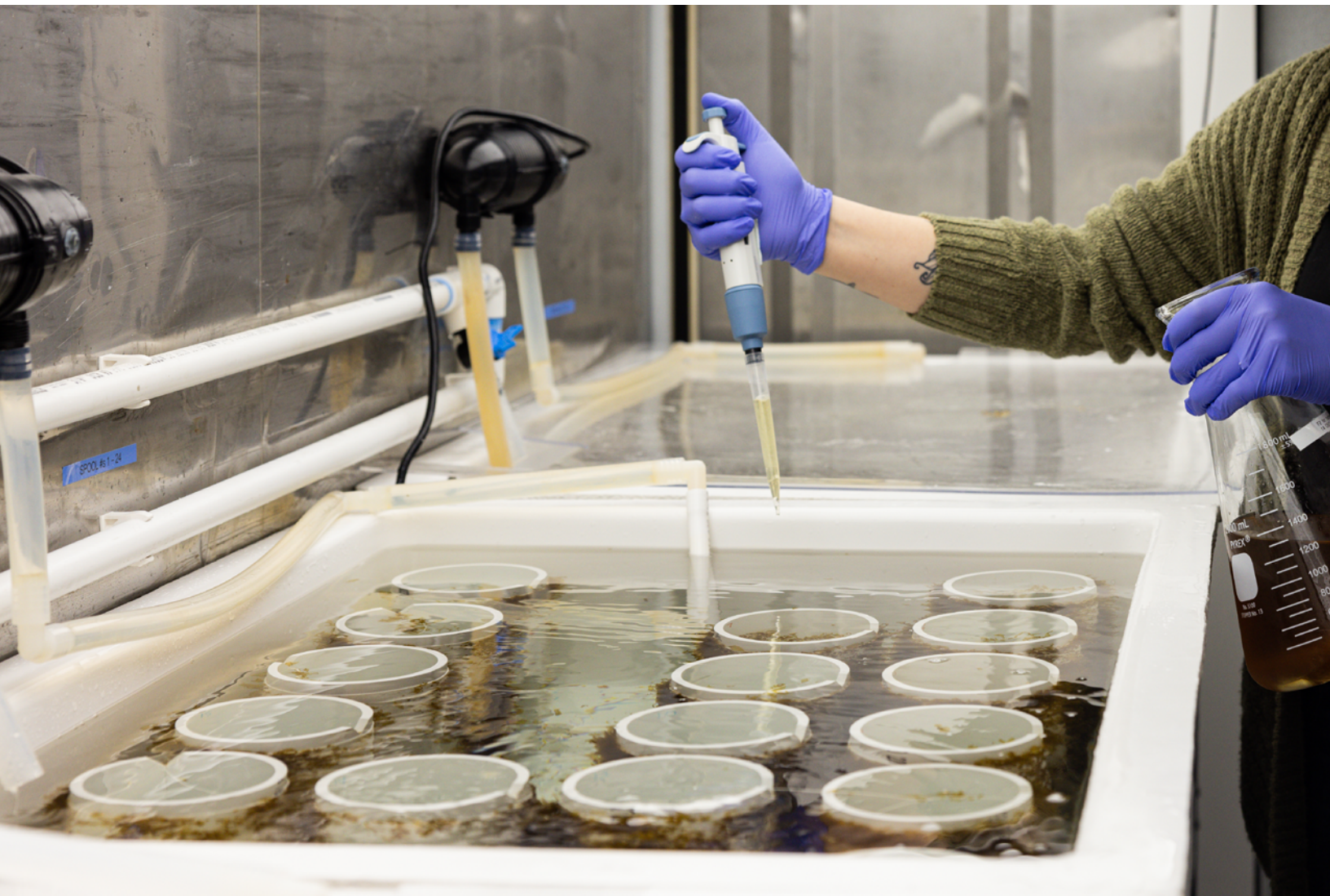

CARING FOR SPOOLS IN THE NURSERY



Watch video: [Microscope demonstration](#)

GreenWave uses a stereo microscope to take images of juvenile sporophytes and any potential contamination.

“

Regularly check a representative spool from each grow tank under the microscope. Early detection of contaminants like diatoms allows for earlier and more effective treatment.”

— Maggie Aydlett

GreenWave, Connecticut

The care for gametophyte-painted spools and spore-seeded spools differs slightly, but the general rules remain the same based on the life-stage, which can be assessed under the microscope. Once spools are seeded, they require close monitoring. Compromised water quality, inaccurate light levels, or improper nutrient levels can all have significant negative effects on the spools. Stressful conditions will have a bigger impact on sporophytes when they are beginning to form than when they are grown out. If the light is too high, the sporophytes may bleach, but if it's too low, the sporophytes will grow too slowly and the total time in the nursery will increase. More time in the nursery means more resources used. There is no major risk to the sporophytes if nutrient levels are too high, but excess nutrients may allow contaminants to grow faster and also result in wasted materials. Use the [Environmental Conditions Chart](#) to know what conditions are right for each spool stage.

Keep track of spool maintenance and conditions in the tanks throughout the nursery season with log sheets. There is a lot of information to be collected from each tank each day, so tracking will be useful when planning for other seasons, tracking failures, and recording contamination outbreaks. An example of a tracking sheet can be found [here](#). Make sure anyone who is operating your nursery is familiar with log sheets and is using them consistently. Each day you will want to do three categories of checks:

1. Environmental conditions check
2. Health check
3. Equipment/system check



CARING FOR SPOOLS IN THE NURSERY

Environmental Conditions Check

To ensure that the conditions in your tank are optimal for seed, you will need to check pH, temperature, and salinity, as well as adjust light levels, flip/turn your spools, and add nutrients. Your goal in the nursery is to create the perfect environment for juvenile kelp.

- **pH:** The pH in your tanks should stay within 7.0–9.0. Remember that pH is a logarithmic scale, so small decimal places can actually mean a significant difference in conditions, especially as you get further away from 7.0. You can find a decent pH meter for relatively cheap. GreenWave prefers the Hanna brand [pH meter](#) or [combo probe](#).



- **Aeration:** Aeration is important in your grow tanks to create water movement around your spools and help manage the pH. You can use [aquarium air pumps](#) and air stones or air manifolds to achieve this. For any air going into your tank, use [in-line air filters](#).
- **Salinity:** Salinity in your tank should be between 28–34 ppt. You can measure the salinity with a [refractometer](#). Your exact numbers may vary based on the region you are growing in. It is best to compare your tank conditions to the natural water conditions from your collection locations. If you are pumping in seawater, the salinity will normally be within the safe range as long as you are not pumping from an area with a lot of freshwater input. Evaporation in your nursery can also impact your salinity. If you have a lot of evaporation from your tanks in your nursery, monitor the salinity very closely and consider using tank covers. If your salinity gets too high, do a 50% water refreshment. If the salinity of your water source is too low, you may need to supplement with [Instant Ocean](#).
- **Temperature:** The water temperature in your tanks should be 10–12°C (50–54°F). Colder temperatures may slow growth, but they can also help reduce the risk of contaminants. Warmer temperatures may initially increase growth, but once they rise too high, they will stress the kelp and reduce growth. Elevated temperatures can also accelerate the spread of contaminants.



Small details can reveal a lot about water quality. Bubbles from aeration that linger on the surface without popping or show an oily sheen often signal problems such as residual chemicals or contamination overgrowth.

CARING FOR SPOOLS IN THE NURSERY

- **Light levels/cycles:** Check that your light timers are working weekly. Adjust the light levels for your tanks according to the [Environmental Conditions Chart](#). Use a full spectrum PAR meter to measure light levels. GreenWave uses this [Apogee PAR meter](#). Measure the PAR from a position that is similar to the spools' positions. At GreenWave, we use top lights so we measure the par from the top of the water column, about 1–2 inches below the water surface.



- **Nutrients:** Your kelp needs ample nutrients to fertilize and grow. GreenWave uses an F/2 solution made from [F/2 powder](#) for dosing our grow tanks. Since we have flow-through tanks that refresh at 100% daily, we dose with 1 mL of F/2 per 10 L of seawater in our tanks two times per day, typically around 8:00 am and 5:00 pm. This number may change if you don't have flow-through tanks or aren't changing 100% of the water per day. You can refer to the [Environmental Conditions Chart](#) to see how the dosing changes throughout the season.

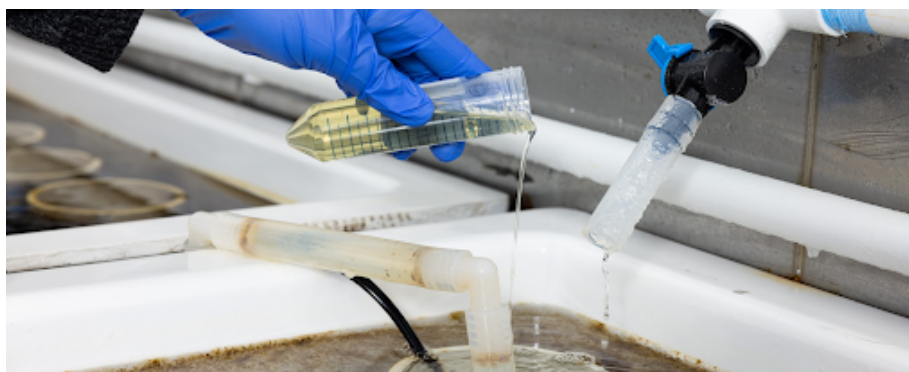

Watch video: [Flipping spools](#)

Flipping your spools, when using top light, and turning them, when using side light, helps promote even growth.

- **Flip/turn spools:** Depending on your light source, you will need to either flip or turn your spools once every two days. For top lighting, flip spools. For side lighting, turn spools. However, if you are using LEDs and lighting from the side, you may need to both flip and turn your spools to avoid banding.

CARING FOR SPOOLS IN THE NURSERY

Health Check

Observe and take pictures of your tank each day. Look for changes in coloration, signs of contamination, and growth. In a perfect season, you'll see nothing except deep brown baby kelp blades growing on your spools and in your tanks. You can use the [Spool Growth Tracking Chart](#) to give you an idea of the timing of your nursery and what type of growth you can expect at each stage.

It can be hard to see the difference in growth if you are looking at your spools daily; this is why taking pictures of your tanks daily is good practice. Issues with blade health and contamination happen very quickly and can be catastrophic if not caught early. Issues with blade health are normally due to environmental conditions that can often be corrected with a quick fix. However, contamination issues might require active maintenance and can add a significant workload to your nursery season.

You can use the [Contamination Identification for Spools](#) and [Contamination Treatment Chart](#) to help you determine the best course of action.

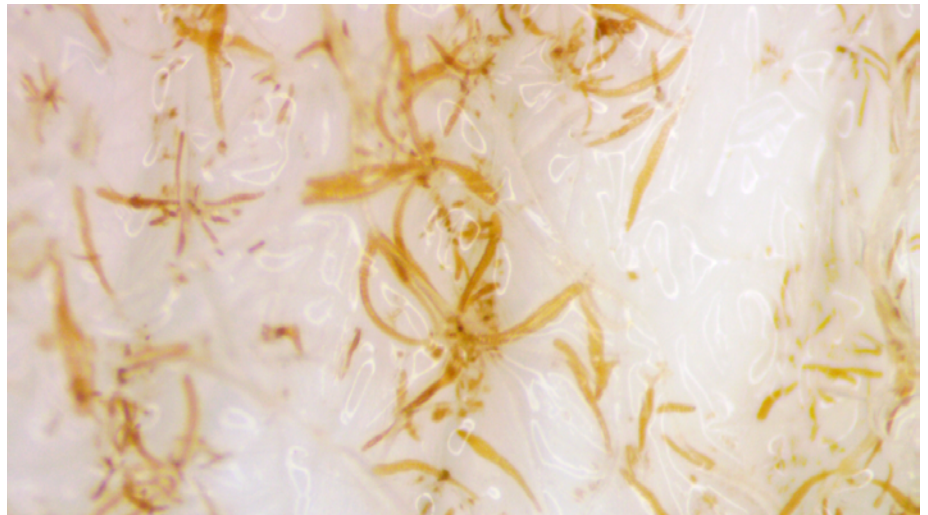

A healthy spool with many visible sporophytes viewed under a stereo microscope after three weeks in the nursery.

Each week, check the health of your spools under the microscope. This is best done under a stereo microscope, or another microscope with a large stage. If you only have access to a compound microscope, you may have to cut small pieces of seedstring or take scrapings from the seedstring to check the health. However, this method does not give the full picture of the growth on the spool.

CARING FOR SPOOLS IN THE NURSERY

Equipment/ System Check

Your nursery system has a lot of moving parts. If an integral part stops working, you can have nursery failures. Because of this, it is important to check to make sure your system is in working order each day. Common issues might include air or water filters clogging, light timers breaking or getting off schedule, or cooling equipment breaking or lagging. It is also important to check that your drains are draining properly, you don't have any dirty stagnant water, and your water inflow is the right strength. GreenWave keeps our water flow into each tank at 100% daily for the first few weeks of the season, so we measure the inflow into each tank volumetrically every couple of days.



This water pump from a nursery tank is clogged with sporophytes. The intake should be cleared out using a clean brush or paper towel.

“

“Keep a binder with copies of all equipment manuals in the nursery. Having these references on hand ensures you can quickly troubleshoot and address issues as they arise.”

— Lexa Meyer

Alaska Ocean Farms, Alaska



The difference between the UV lamp off (left) and UV lamp on (right) is subtle. It's important to check your system carefully and frequently.

CARING FOR SPOOLS IN THE NURSERY

Troubleshooting

Each nursery system is unique and may run into its own specific problems. Troubleshooting will look different for everyone, but it is never a bad idea to reach out to other nursery operators you know for help.

You can use the Community section of GreenWave's [Ocean Farming Hub](#) to post questions and join conversations about nursery troubleshooting.

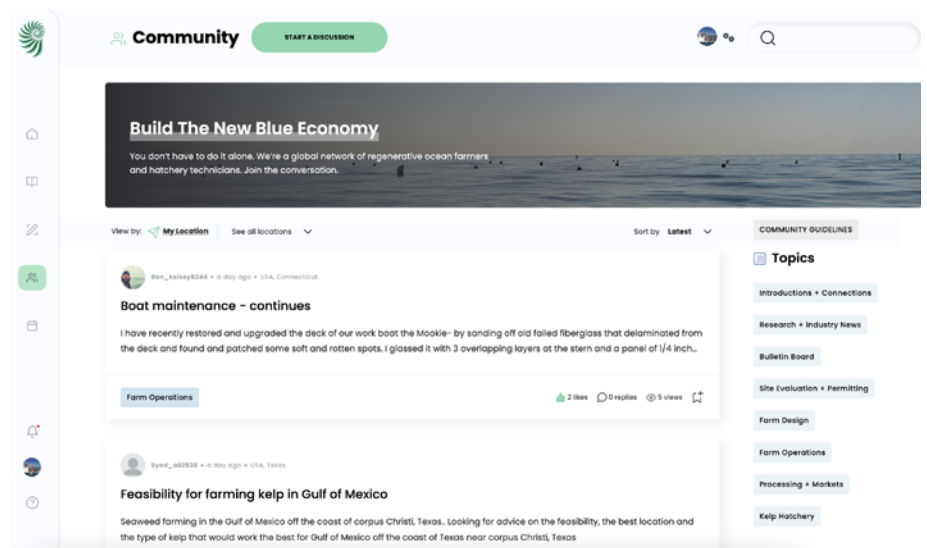

PART 09

SEED ORDERING



SEED ORDERING

Put a system in place to track spool orders before your nursery season starts. This system can be as simple as a paper log that you update as people inquire. As you are gearing up for your season, reach out to anyone on your list interested in buying spools from your nursery to tally a more exact number. Often, a farmer may not know their exact plan for farm size or the number of lines they would like to plant until they are also getting ready for their season. GreenWave uses an August 31 cutoff for spool orders. Make sure your deadline gives you enough time to make adjustments to your system setup if needed. It is also helpful to set reasonable limits for your nursery prior to committing to seed spool orders. Following these steps will help you plan your nursery season and keep an open line of communication between you, the seed supplier, and the farmers you supply to:

1. Check in with farmers at the end of the harvest season to see how your seed performed.
2. In mid-summer, contact farmers to remind them of important dates, like the spool order cutoff date, and notify them of any changes to your operations that you will be making in the upcoming season.
3. One week before your spool order cutoff, remind farmers that orders are due soon.
4. Within a few days of your order cutoff, total up the orders and compare them to your predetermined nursery capacity. If you cannot commit to getting every farmer all of the spools they would like, let them know as soon as possible so they can order additional spools from another nursery.
5. Confirm the orders with the farmers and notify them of the expected timeframe that they will be able to pick up their spools. Inform the farmer of the conditions for spool ordering that they are agreeing to and have them sign the contract. We've included an example of GreenWave's spool ordering contract in this section.
6. Once your season is underway and your spools are almost ready for distribution, remind farmers of the pickup timeframe. GreenWave typically sends this reminder two weeks before the spools will be ready and provides a timeframe of two weeks for pickup. Include an update on spool quality in the email.
7. As the seed spool pickup timeframe nears, coordinate pickup times with farmers. Let them know what materials to bring and how to best handle the spools after they take them from your facility. After the spools leave your facility, they are the farmer's responsibility.

SEED ORDERING

8. Soon after the seed spool pick up window is over, remind farmers to return their empty spools. It is important to get your spools back to save you the time it takes to make new spools, as well as to prevent excess nursery waste. Consider collecting a spool deposit from farmers that is returned to them when they return their empty spools as an incentive to return spools in a timely manner.
9. Keep in touch with your farmers during the season to gauge the success of your seed.

It is important for you as a seller to set and communicate reasonable expectations to your buyers. One way to do this is through a contract. The contract does not need to be long or complicated, but it does need to clearly outline what both the nursery and farmer can expect from each other and where the nursery's responsibility ends and the buyer's responsibility begins. Send this contract to the farmers when you confirm their spool order. The contract should include points on pricing, timing, seed quality, a chain of custody of spools (i.e. who is responsible for the spools at what points), and what happens if your seed does not meet the farmer's standards. We've included a sample contract on the next page. Use this as a guide to draft your own contract that reflects the terms and best practices of your nursery operation.



Nursery-Buyer Contract

By signing this form, you are consenting to the terms as described below.

Cost & Payment

- All sales must be **paid in full** at the time of pickup, or before product will be delivered or shipped. The cost of each spool is **COST**.
- Orders requiring delivery/shipping will have delivery/shipping costs added to an additional invoice.
- A **COST** per-spool refundable deposit is due in cash at the time of pickup.

Expectations of the Nursery

- We will grow spools for you based on the **confirmed** order of spools from the beginning of the season. We will only have the number of spools that we confirmed, which may be a lower number than your original request was for.
- We will only sell spools with a high-quality ranking (8+), based on the criteria outlined in the [Spool Quality Assessment Guide](#). The cost of lower-quality spools will be prorated based on their quality. The quality of a spool is only guaranteed during the suggested pickup window.
- In the instance of seed failure or contamination outbreaks during the season, we will notify you as early as possible and let you know how it impacts your order.
- If you require your spools to be shipped, we will first send you pictures of each of your spools and ask for your confirmation of quality. Once accepted, we will package and ship your spools based on our shipping methods, unless otherwise requested. Once the spools leave our facility, we are no longer responsible for them. Shipping spools, rather than pickup, is risky; that risk is assumed by the buyer.

Expectations of the Buyer

- The buyer is obligated to purchase the number of spools that is indicated on their order confirmation, so long as the nursery is providing high-quality seed. Exceptions may be possible, but are not guaranteed. If the buyer's plan changes after the start of the nursery season, they should let the nursery know as soon as possible to discuss.
- The buyer has the right to, and should, reject a spool at pickup if they don't agree with the quality evaluation. This right is waived if the farmer is receiving spools as a shipment from the nursery, but they will be provided pictures of the spools prior to shipping and can decline them based on quality at that time.
- The buyer is responsible for bringing a cooler and cold packs to the nursery facility at the time of pickup. The nursery will not provide additional packing, insulation, or cooling packs. Please refer to the spool transportation guidelines if you are unsure what packaging to bring.
- PVC spools are to be returned within 30 days of outplanting; your deposit will be returned at this time. If the spools are returned after 30 days, a returned spool deposit is not guaranteed.

For questions, contact **NAME** at **NURSERY**.

Buyer signature: _____ Date: _____.

Nursery operator signature: _____ Date: _____.

SEED ORDERING

Having a contract helps both parties align expectations. A farmer should refuse spools that do not meet quality standards, and a nursery should inform farmers before pickup if this might be the case. Determining the quality of a spool can be difficult because there are many factors at play such as total coverage, health/color of the sporophytes, size of the sporophytes, and presence of contamination. You can use the [Seed Spool Quality Grading Guidelines](#) chart, along with the [Contamination Identification for Spools](#) to help you understand why each of the factors is important and determine the overall quality of spools.

Transporting Seed Spools

Once spools are ready for outplanting, they will need to be transported either by farmers or by shipping. There are three important things to consider: moisture, temperature, and avoiding contact with fresh water. Transport the kelp in a moist environment to prevent the juvenile blades from drying out or sticking to each other. This can be achieved by wrapping the spool in paper towels soaked in seawater or laying some sort of damp cloth over the spools in a cooler. Just before a seed spool is outplanted, allow it some time to soak in the seawater so the blades can loosen up and unstick. Keep the seed spools chilled, ideally between 10–12°C. The juvenile kelp is more tolerant to temperature changes than it is to drying out, so slightly higher temperatures during transport do not normally result in seed death. Lastly, the kelp should not come into contact with any freshwater. Freshwater will cause the blades to bleach and turn green very quickly, and the blades will not recover. Because of this, place any cooling packs at the bottom of the container. If they are placed at the top, you risk condensation dripping down onto the spools.



If you are shipping spools, be sure to notify the recipient before sending them out. This gives them time to prepare to receive the spools. After you put them in the mail, send the tracking information. If you are mailing the spools with an airline, there may be additional pickup directions. It is good practice to have a contingency plan in place in the event of weather delays.

SEED ORDERING

Protocol for Seed Spool Transportation

Ensure your work area is clean and sterilize any surfaces that will be used with a generous amount of ethanol.

1. Gather supplies:

- Gloves
- Ethanol spray bottle
- Paper towels or thin towels
- Spool log sheet
- Seed spool
- Styrofoam cooler
- Cardboard box
 - Some shipping services will require you to pack your cooler inside a cardboard box for shipping.
- Ice packs
- Packing material

2. Identify the seed spools that need to be packed.

3. Record the date of the spool leaving the nursery, the spool quality, and the recipient of the spool on a spool log sheet.

4. Prepare your cooler by placing the cooling packs at the bottom and layer with packing material.

- If you are shipping spools to a farmer, make sure they will be present to receive the package after it is sent, and avoid shipping the package on days leading up to a carrier being closed.

5. Using gloved hands, wet a sheet of a few paper towels with seawater and remove the seed spool from the tank.

6. Gently wrap the spool in the wet paper towels so the entire spool is covered.

7. Follow this procedure for the rest of your spools.

8. Pack your spools in the cooler.

- It is okay for the spools to be touching each other as long as they will not jostle around.



SEED ORDERING

9. Layer as much packing material as necessary on top of the spools to prevent them from moving around.
 10. Seal the cooler.
 11. If required, pack your cooler inside a cardboard box for shipping.
 12. If shipping the spools, store the box in a cold chamber until you are ready to bring them to the carrier.
 13. Provide the recipient with tracking information and monitor the progress of the shipment.
-

PART 10

REFERENCE DOCUMENTS



Environmental Conditions Chart

Stage	Substage	Temp	Light	Water Type	Nutrient Additions	Maintenance
Spools	First 24 hours	50–54°F 10–12°C	Dark 0umol	Sterilized	F/2 1mL/10L 2x per day	n/a
	Days 2–3	50–54°F 10–12°C	White 20umol	Sterilized	F/2 1mL/10L 2x per day	Refresh water 100% daily
	Days 4–5	50–54°F 10–12°C	White 40umol	Sterilized	F/2 1mL/10L 2x per day	Refresh water 100% daily
	Days 6–7	50–54°F 10–12°C	White 60umol	Sterilized	F/2 1mL/10L 2x per day	Refresh water 100% daily
	Days 8–14	50–54°F 10–12°C	White 80umol	Sterilized	F/2 1mL/10L 2x per day	Refresh water 100% daily
	Days 15–21	50–54°F 10–12°C	White 100umol	Sterilized	F/2 1mL/10L 2x per day	Refresh water 75% daily
	Days 22–28	50–54°F 10–12°C	White 120umol	Sterilized	F/2 1mL/10L 1x per day	Refresh water 50% daily
	Slow growth	50–54°F 10–12°C	White 40umol	Sterilized	F/2 1mL/50L as needed	Refresh water 10% as needed

Contamination Treatment Chart

Contamination Type	Type	Stage	Severity	Description	Treatment	Maintenance
Diatoms	Any shape	Seed spool	Low	Clusters begin popping up on the sides of tanks or at the ends of spools.	Germanium dioxide (GeO2)	Add 1mL/10L of GeO2 solution to each tank 1x per day until you don't see additional diatom growth. If possible, avoid using GeO2 before day 14.
			Medium	Clusters are large and growing in diameter or begin to pop up on seedstring.	Germanium dioxide (GeO2)	Treat as above. Additionally, wipe the clusters away with a clean paper towel or sponge where possible. Avoid dropping diatoms in the tank.
			High	Spools and seedstring are covered in a light brown color.	Germanium dioxide (GeO2)	Treat as above. Additionally, rinse seedstring with a low flow of clean water until the diatoms wash away. Avoid splashing rinse water into other tanks.
Cyanobacteria	Attached	Seed spool	Low	Blue or green streaks or clusters are visible on the sides of the tanks or spools.	Manual	Streaks typically appear closest to the light. Wipe clusters away with a clean paper towel or sponge where possible. Avoid dropping contaminants back into the tank.
Ectocarpus	Tufts	Seed Spool	Low	Stringy tufts of ectocarpus begin to appear in tanks or on the spools.	Manual	If there are only a few tufts, leave them be. If many new tufts begin to develop on spools, use a pair of tweezers to gently pull the tufts off. Avoid fragmenting the tufts.
			Med	Stringy tufts of ectocarpus develop all over tanks or on the spools.	Manual	Closely monitoring your spools will prevent you from getting to this point. The above treatment is the only treatment. If you allow ectocarpus to take over, you risk your spools being smothered.

Contamination Type	Type	Stage	Severity	Description	Treatment	Maintenance
Bacteria	Attached	Seed spool	Low	Small amounts of bacteria are seen on the spool surface and appear stringy or as a color cluster.	None	Small amounts of bacteria are normal in your tank system and do not require treatment. If a bacteria problem worsens, it may begin to smother your spools and should be considered "high severity".
			High	Slimy film that coats seed appears on the surface of spools.	Manual	Manually remove the film as best you can. Avoid disturbing the seed as much as possible.
	Free-floating	Seed spool	Low	Free floating mats appear on the surface of water in tanks.	Manual	Use a clean object to push the bacteria toward the drain.
	Foggy	Seed spool	Low	Water appears slightly cloudy.	Manual	Perform an extra water change. If the problem persists for multiple water changes, consider severity high.
High			Water appears cloudy for multiple days, even after water changes.	Kanamycin	Add 5mL of kanamycin solution per 10L of seawater to each tank 1x per day until you don't see cloudiness. If possible, avoid using kanamycin before day 14.	
Protozoa	Free swimming	Seed spool	Low	Water appears silky or foggy and protozoa are visible under microscope during water check.	Manual	The daily water change of 100% should prevent this issue. However, if the water appears very foggy, do an extra complete water change.
Fungi	Any type	Seed spool	Low	Clusters begin to appear on surfaces in tanks or on the surface of the water.	Manual	Use a clean object to push the clumps on the surface toward the drain or use a clean paper towel to gently wipe the spot away.

Greenwave Water System and Nursery Diagram

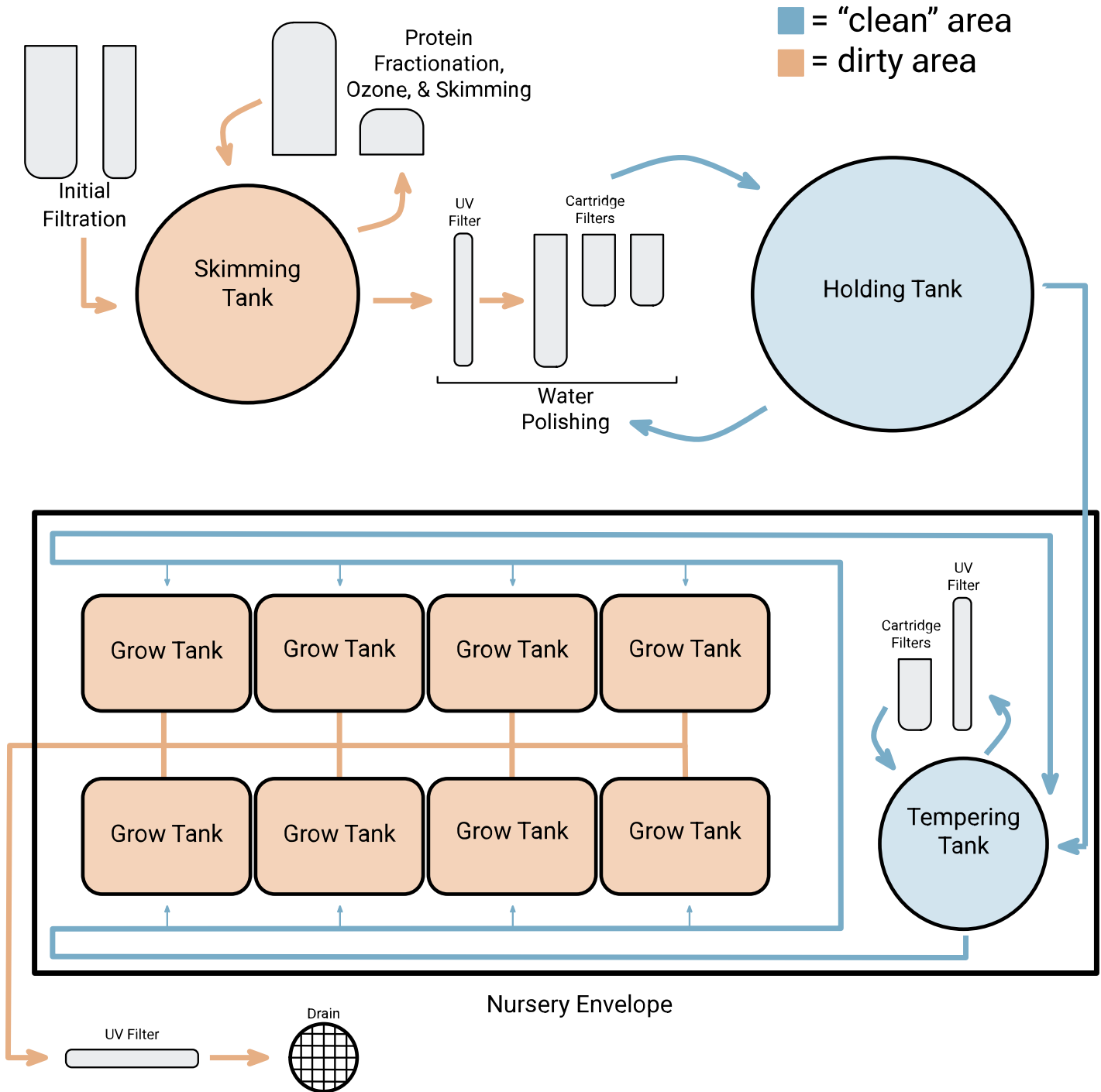

Contamination Identification for Spools

Bacteria

Bacteria show up on spools in many different ways. Sometimes an outbreak in bacterial contamination is due to inadequate water supply, but other times the outbreak happens as a result of bacteria present in the gametophyte cultures or spore solution. Typically, bacterial contamination is manageable.

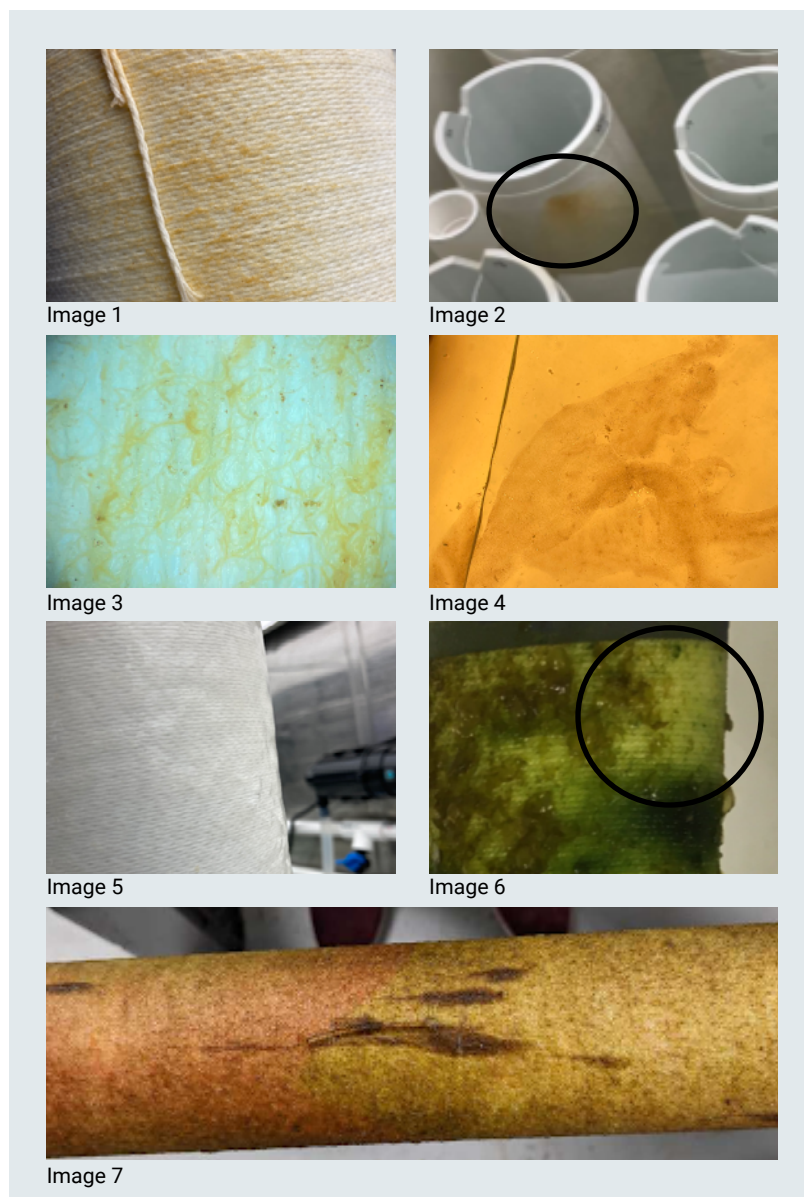

The most common bacteria that we see (images 1 and 2) is a yellow bacteria that appears on spools near high flow areas. In our tanks, we see this near the inflow, the outflow, and around the pump intake. Under the microscope, the bacteria appears stringy (image 3). Sporophytes are usually able to outgrow this type of bacterial contamination without any problem, however if a thick film appears, it may cause an issue.

Some bacterial outbreaks (images 4 and 5) can pose a threat to the health of your spools by completely smothering the developing sporophytes. In this case, the bacterial slime was so thick that it could be pulled off in slimy sheets. Unfortunately, when the slime is pulled off, many sporophytes come off with it. In addition to sporophyte loss, a contamination like this also takes significant time to mitigate.

Cyanobacteria are a subset of gram-negative bacteria that use photosynthesis. They are usually colored, relating to their ability to photosynthesize. The most common cyanobacteria we see is green (image 6). It appears as a thin coat of green that is over the entire spool, not usually patches. Another type of cyanobacteria is pink (image 7). Typically the pink cyanobacteria appears in patches on the spool.

Microalgae

Many of the contaminants that appear in gametophyte cultures are microalgae. Microalgae are single-celled organisms, although they often exist in chains or groups. Single cells are not big enough to be visible by eye, but groups of them are. Most microalgae we find on spools are blue/green.



Image 8

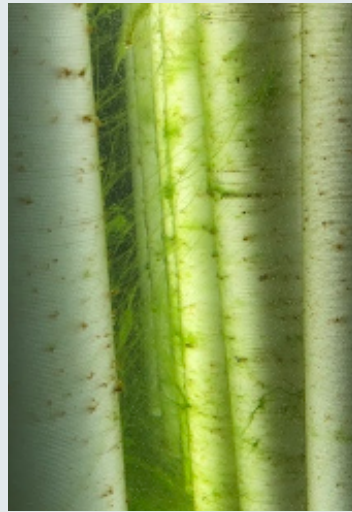

Image 9

Green microalgae grows in chains that look stringy or webby at a macroscopic scale (image 8). If left unchecked, the algae will grow quickly and attach to the spools (image 9), eventually smothering the gametophytes and sporophytes. There is no chemical treatment for the contamination, but small strands can be scooped out as they appear to avoid extra growth.

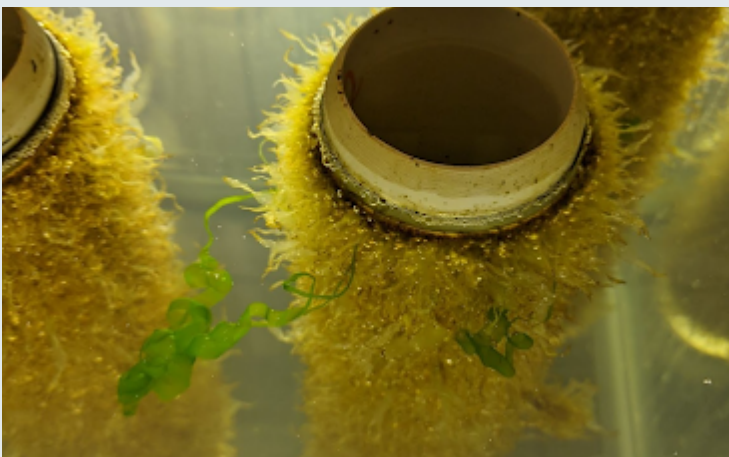

Image 10

Other Macroalgae

Occasionally, other macroalgal species make their way into tanks. This is more common when spore seeding than when gametophyte seeding. The most common macroalgal contamination is ulva (image 10). Macroalgae contamination can be remedied easily, if caught early, by removing the blades with sterile tweezers.

Ectocarpus

Ectocarpus is a filamentous brown alga. It looks similar to kelp when growing on a spool. When the ectocarpus is fully grown, the differences are visible.

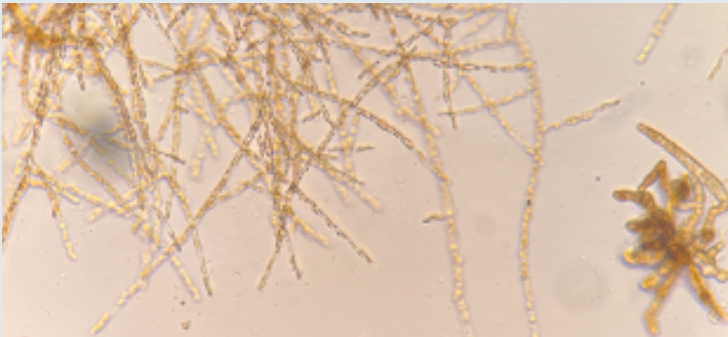

Image 11

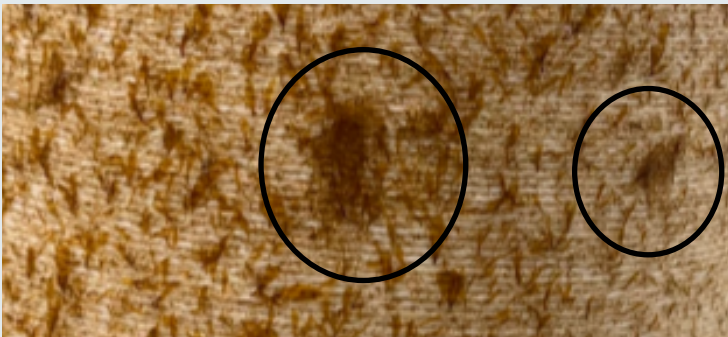

Image 12



Image 13

You can distinguish between kelp and ectocarpus under the microscope in three main ways:

1. Cell fill - Under the microscope, ectocarpus cells look “emptier” than kelp (image 11).
2. Color - Under the microscope, ectocarpus is a lighter color than healthy kelp gametophytes (image 11).
3. Morphology - Both kelp gametophytes and ectocarpus branch in similar ways, but ectocarpus has more long single shoots that branch out from the main shoot (image 11) and appears stringy (image 13).

Since kelp and ectocarpus are both brown alga, it is not possible to kill the ectocarpus without damaging the kelp. Instead, you can treat low level ectocarpus contamination with manual measures. For spools that look like image 12, you can use tweezers to gently pull the clumps of ectocarpus from the string. Spools that look like image 13 are not treatable because there are so many new tufts of ectocarpus forming. If your spools have developed sporophytes already, the sporophytes may still be able to outcompete the ectocarpus.

Diatoms

Diatoms are a type of protist; we list them separately because they are treated in a different way than other protists. Diatoms appear in cultures in a few different morphologies and have cell walls made of silica. Diatoms are a threat to cultures because they graze on the kelp and grow much faster, smothering the seed.

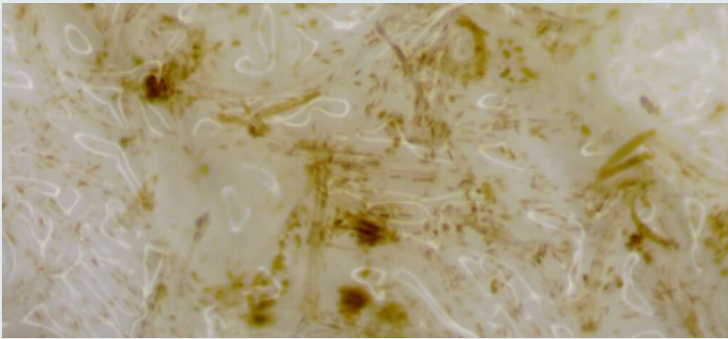

Image 14



Image 15





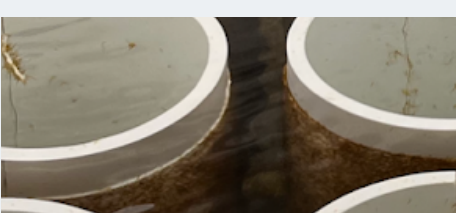
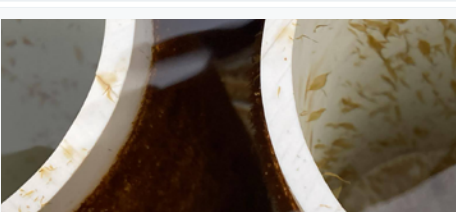

Image 16

When diatoms appear in a tank, they can take off very quickly. Monitor your spools closely to avoid a major outbreak. Because diatoms are photosynthetic, you will see signs of contamination closest to the light source first. If left unchecked, the diatoms will smother the sporophytes (image 14). Initial signs of diatom contamination are small brown spots on the walls of the tank or surface and edges of the spools (images 15 and 16).

Because of the unique cell wall structure of diatoms, there is a chemical way to treat them. Dosing a culture with germanium dioxide prevents new growth. It is important to treat diatoms early because the GeO₂ treatment does not kill already existing diatoms, but instead prevents new growth.

Spool Growth Tracking Chart

Spool Speeding Timeline	Gametophyte Seeding Timeline	Notes	Images
Days 0–14	n/a	For the first two weeks after seeding, it will be hard to tell what is happening on your spools. They may darken slightly, but the change will be subtle. During this time, it is important to monitor your tanks very closely for signs of contamination.	
Days 15–21	Days 0–7	During this time, the spools will darken as the gametophytes grow and microscopic sporophytes form. For gametophyte seeding, the spools will have a light color as soon as they are painted.	
Days 22–28	Days 8–14	At this stage, you will begin to see very small sporophytes on your spools with the naked eye. It will be easiest to see these from a top view or under the microscope.	
Days 29–35	Days 15–22	By the fourth week, you will be able to see well developed sporophytes on your spool. It may help to gently shake your spool in the water to see the small sporophytes sway back and forth.	
Days 36–42	Days 22–28	During the fifth week, your spools will continue to darken as your sporophytes grow. You will see variation along your spool depending on your lighting style. For top lighting, sporophytes on the ends of the spools will be bigger than those in the middle.	
Days 43–49	Days 29–35	At this point, your spools should be outplant ready and the majority of the sporophytes in the middle of the spools will be 3–5 mm long.	

Seed Spool Quality Grading Guidelines

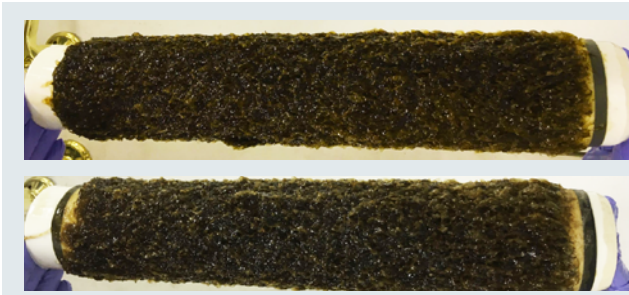

Excellent (10-9)

An excellent seed spool is one that has uniform growth across the spool and shows no signs of contamination or sporophyte stress. It is common for the first few wraps on the top and bottom of the spool to have a lower density kelp; this does not influence the spool grade except for instances where the blank space extends down the spool.

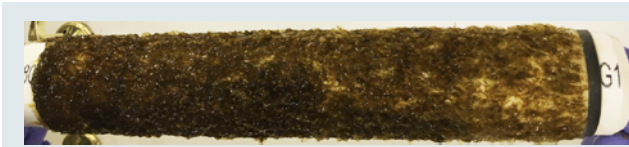

Good (8)

A good seed spool has healthy looking sporophytes and uniform growth, but may be a little less dense than an excellent spool.

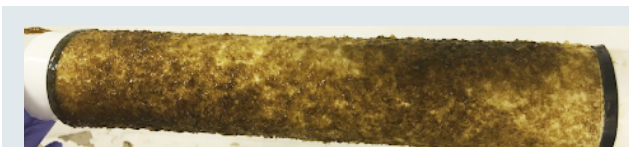

Acceptable (7)

An acceptable spool has uniform growth and sporophytes that may be slightly discolored.



Unacceptable (6-0)

Even if a spool has uniform coverage, it can still be unacceptable for other reasons including bleached blades and contamination.

Bleached blades can result from various factors in the nursery. If blades are too bleached, they will not be able to recover. However, some lighter colored blades may recover and grow fine. The line between unrecoverable and recoverable is difficult to assess, so it is best to err on the side of caution.

Some contaminations do not pose a major threat to seed and will still result in good yield. Small amounts of ectocarpus and diatoms are among this group. However, high densities of ectocarpus, diatoms, bacteria, and cyanobacteria can smother spools and cause blank spots or blank spools. Avoid spools that appear slimy, green, or pink.

Spool coverage is a main indicator of how well a spool will perform. Do not use spools that are very spotty or have no visible growth, as these are a result of bad spore settlement or contamination.

Media and Solutions Chart

Solution	Concentration of Stock	Concentration in Cultures	Concentration in Tanks	Storage
<u>F/2 powder</u>	100g per 1L SW	1mL per 1L SW	0.22mL per 1L SW	Keep refrigerated. Use within 3 months.
<u>F/2 jugs</u>	1mL part A per 1mL part B	0.129mL of each part per 1L	0.22mL per 1L SW	Keep stock jugs refrigerated. Use new made stock within 3 months.
<u>Kanamycin</u>	1g per 100mL (DI water)	5mL per 1L SW	n/a	Keep refrigerated. Use within 2 weeks.
<u>Germanium Dioxide (GeO2)</u>	0.1g per 200mL (DI water)	0.5mL per 1L SW	0.11mL per 1L SW	Keep refrigerated. Use within 6 months.

© 2025 GreenWave.

Support for this resource was provided by **Alaska Sea Grant** and the **Alaska Mariculture Cluster**, a project of **Southeast Conference** funded by the **U.S. Economic Development Administration (EDA)**.



UA is an affirmative action/equal opportunity employer, educational institution and provider and prohibits illegal discrimination against any individual:

www.alaska.edu/nondiscrimination.